

Application Note

Magnetic Position Sensing in Brushless DC Electric Motors

1.0 INTRODUCTION

This application note discusses regulating the electronic commutation in brushless DC electric motors (BDCMs) with the following Honeywell Hall-effect sensor ICs in place of the mechanical commutation used in conventional brush-type DC motors:

- Enhanced digital bipolar (SS30, SS31x/SS41x Series)
- Bipolar latching (SS36x/SS46x Series)

BDCM technology, coupled with SS Series Hall-effect sensors, provides a cost-effective and reliable alternative to conventional DC motor commutation. Manufacturing and operating cost savings can be realized in several areas:

- Honeywell Hall-effect sensors are relatively low-cost devices
- The sensors' low operate and release Gauss levels (at 25 °C ±40 °C) allow the manufacturer to install lower-cost commutation magnetics
- These solid-state sensors have no moving parts to wear out, eliminating maintenance and performance problems created by brush wear and the associated dust.

2.0 OVERVIEW

Brushless DC motors differ from brush-type DC motors in that they employ electronic (rather than mechanical) commutation of the windings.

Figure 1 illustrates how this electronic commutation can be performed by three digital output bipolar or bipolar latching sensors. Permanent magnets mounted on the rotor shaft operate the sensors. The sensors communicate the angular position of the shaft to a logic circuit, which encodes this information and controls switches in a driver circuit. The windings then alternate in polarity, in effect rotating in relation to the shaft position. The windings react with the field of the rotor's permanent magnets to develop the required torque.

Figure 1. BDCM Sensors

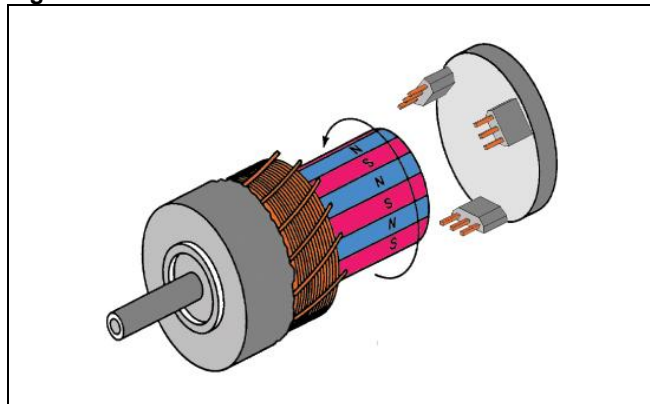

Because no slip rings or brushes are used for commutation, friction, power loss through carbon buildup and electrical noise are eliminated. Electronic commutation also offers greater flexibility in interfacing directly with digital commands.

The long maintenance-free life offered by BDCMs makes them suitable for potential applications such as portable medical equipment (kidney dialysis pumps, blood processing equipment, infusion pumps), ventilation blowers for aircraft and marine submersible motors.

3.0 THEORY OF OPERATION

BDCMs are essentially brush-type motors turned inside out. Power is fed directly to the armature windings, while a permanent magnet rotor is the rotating member. Depending on the design, the motor can be either inner or outer rotating. Also, the brushes and commutator of a classic DC motor are replaced by position sensors and electronic switching.

Torque, the force that produces motion, is developed in DC motors by the permanent magnetic field interacting with the current flowing through the windings. In brush-type motors, the commutator switches the armature windings in order to provide proper magnetic flux and armature current interaction. In brushless motors, a Hall-effect position sensor IC detects the position of the rotating magnet and excites the proper windings through logic and driver circuitry.

Many types of BDCMs designs are in production today. An eight-pole motor (four pole pairs) with a three-phase winding is shown in Figure 2. Either regular bipolar or bipolar latching Hall-effect position sensor ICs can be used.

Figure 2. Essential BDCM Elements

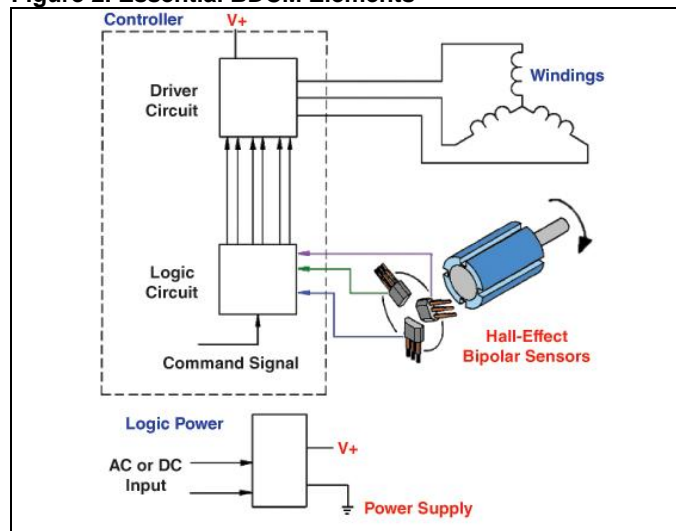

Magnetic Position Sensing in Brushless DC Electric Motors

The rotating permanent magnet moving across the front of the sensor causes it to change state. The sensor operates when each south pole approaches.

Figure 3 shows the output of three sensors placed 30 electrical degrees apart in the BDCM. In an eight-pole magnet BDCM, each south pole is 90 degrees from the next pole. When three sensors are placed 30 degrees apart, the first sensor will operate at 30 degrees, the second at 60 degrees and the third at 90 degrees.

Figure 3. Sensor Operation

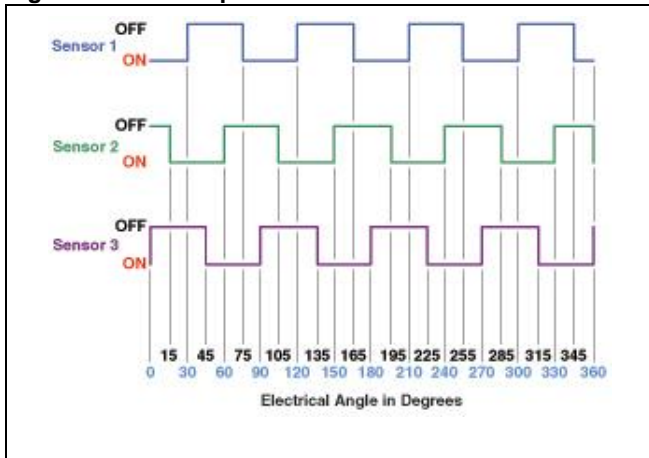

When the north pole passes the sensors, they will release. Each north pole of the rotating eight-pole magnet is 45 degrees from the adjacent south pole. Each sensor will release at 45 degrees after operating.

The three sensor outputs are used as shaft position encoders. The sensor signals magnet position and polarity information to a logic circuit, which switches on power transistors arranged in an “H” bridge formation.

Figure 4 provides an example of a driver circuit using six power transistors and three Hall-effect sensors.

Figure 4. Typical Driver Circuit for Three-phase BDCM

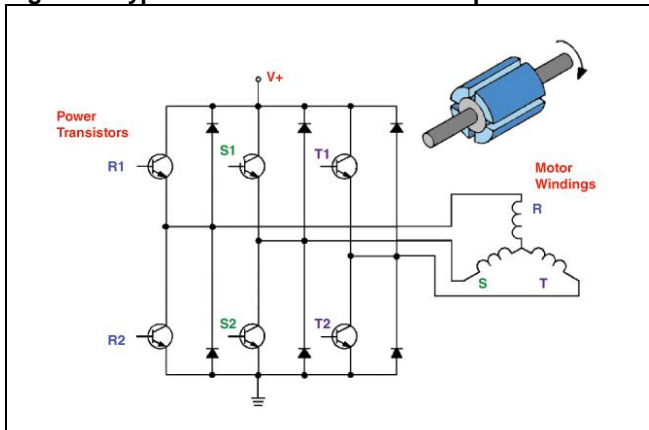

Based on the position of the rotating magnets, each pair of power transistors is correspondingly activated and deactivated, providing current to the armature windings in the appropriate sequence and time.

The sensors can be placed directly inside the motor, at the end of a motor’s shaft, or around a ring magnet attached to the rotor shaft, as illustrated in Figure 5.

Figure 5. Typical Sensor Locations

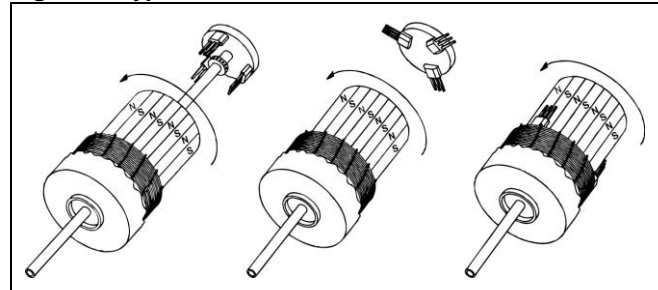

RPM and direction sensing are additional uses for Hall-effect sensor ICs in BDCMs. Multiple discrete Hall-effect sensors or a single package integrating multiple sensing elements, such as the dual Hall-effect sensor VF526DT, would accomplish these functions. The VF526DT series incorporates two digital Hall-effect elements that provide both speed and direction output.

4.0 NEW BIPOLAR AND BIPOLAR LATCHING HALL-EFFECT SENSOR ICs

Honeywell SS30, SS31x/SS41x and SS36x/SS46x Series Hall-effect sensors provide the precise motor shaft positioning data needed by BDCMs. These series include magnetically bipolar or bipolar latching sensor ICs, which have positive (south) operate and negative (north) release points that are nearly magnetically symmetrical over the temperature range. A sensor operating at positive 90 Gauss, for example, will release at approximately negative 90 Gauss.

4.1 Solution

For reliable, accurate, economical BDCM commutation, one of the new Honeywell bipolar or bipolar latching Hall-effect sensor ICs listed below would be an excellent choice:

- **SS311PT/SS411P** Low-cost Bipolar Hall-Effect Digital Position Sensor in SOT-23 (SS3) surface-mount or flat TO-92-style (SS4) through-hole package
- **SS30AT** Enhanced Bipolar Hall-Effect Digital Position Sensor in SOT-23 (SS3) surface-mount package
- **SS361RT/SS461R** Bipolar Latch Hall-Effect Digital Position Sensor in SOT-23 (SS3) surface-mount or flat TO-92-style (SS4) through-hole package
- **SS361CT/SS461C** High Sensitivity Bipolar Latching Hall-Effect Digital Position Sensor IC in SOT-23 (SS3) surface-mount or flat TO-92-style (SS4) through-hole package

Magnetic Position Sensing in Brushless DC Electric Motors

- **SS360NT/SS360ST/SS460S** High Sensitivity Bipolar Latching Digital Hall-Effect Sensor ICs offer a clean output signal and the fastest latch response time in its class. Subminiature SOT-23 surface mount package (SS360NT/SS360ST) or small, leaded, flat TO-92-style package (SS460S).

For complete electrical and magnetic characteristics, mounting dimensions and operate and release points, visit the Honeywell [web site](#) or contact your local Sensing and Control representative (see next page).

4.2 Features and Benefits*

- **Subminiature package size:** SOT-23 Surface-Mount allows highly compact designs
- **Low voltage:** Operation down to 2.7 V* and reduced current support improve energy efficiency
- **Built-in pull-up resistor:** Simplifies interfacing
- **Built-in reverse voltage protection:** Protects IC against damage during assembly
- **Robust design for a wide range of applications:** Operates up to 150 °C [302 °F]
- **High sensitivity:** Maximum operate as low as 30 Gauss typical allows use of smaller magnets
- **Cost effective:** Typically lower cost than traditional Hall-effect sensors

* Specification available in select catalog listings.

Figure 6. Application Cutaway (sensors shown on stationary PC board at the end of the shaft)

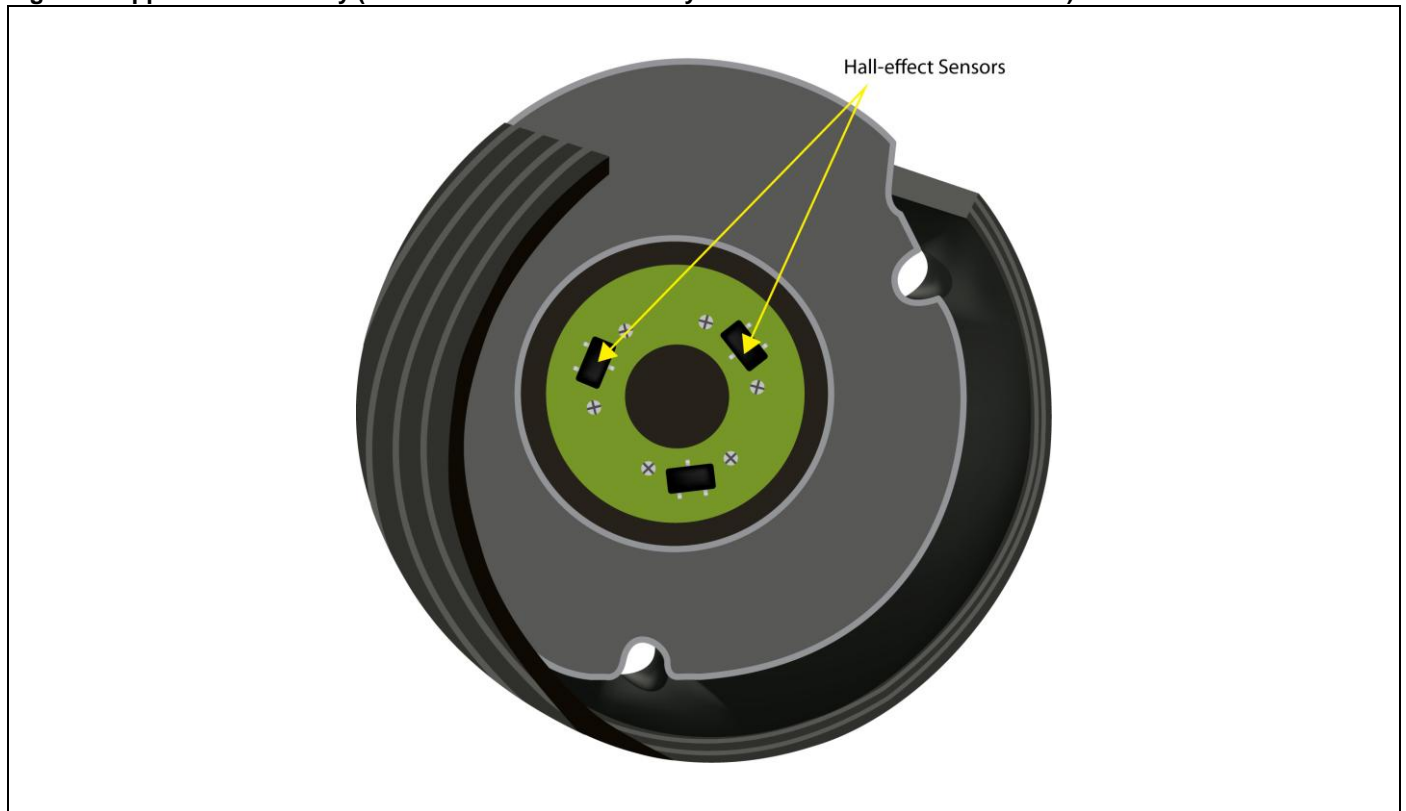

Magnetic Position Sensing in Brushless DC Electric Motors

WARRANTY/REMEDY

Honeywell warrants goods of its manufacture as being free of defective materials and faulty workmanship. Honeywell's standard product warranty applies unless agreed to otherwise by Honeywell in writing; please refer to your order acknowledgement or consult your local sales office for specific warranty details. If warranted goods are returned to Honeywell during the period of coverage, Honeywell will repair or replace, at its option, without charge those items it finds defective. **The foregoing is buyer's sole remedy and is in lieu of all other warranties, expressed or implied, including those of merchantability and fitness for a particular purpose. In no event shall Honeywell be liable for consequential, special, or indirect damages.**

While we provide application assistance personally, through our literature and the Honeywell web site, it is up to the customer to determine the suitability of the product in the application.

Specifications may change without notice. The information we supply is believed to be accurate and reliable as of this printing. However, we assume no responsibility for its use.

SALES AND SERVICE

Honeywell serves its customers through a worldwide network of sales offices, representatives and distributors. For application assistance, current specifications, pricing or name of the nearest Authorized Distributor, contact your local sales office or:

E-mail: info.sc@honeywell.com

Internet: www.honeywell.com/sensing

Phone and Fax:

Asia Pacific	+65 6355-2828
	+65 6445-3033 Fax
Europe	+44 (0) 1698 481481
	+44 (0) 1698 481676 Fax
Latin America	+1-305-805-8188
	+1-305-883-8257 Fax
USA/Canada	+1-800-537-6945
	+1-815-235-6847
	+1-815-235-6545 Fax

Sensing and Control
Honeywell
1985 Douglas Drive North
Golden Valley, MN 55422
www.honeywell.com/sensing

005849-3-EN
June 2012
Copyright © 2012 Honeywell International Inc. All rights reserved.

Honeywell