

# Customer Process Change Notification Form PCN-2011-433

## Part Information

Cirrus Logic Part # / Quantity

CS8421-CZZRCS4391A-KZZR CX4351-CZZRCS4352-CZZR  
 CS8421-DZZRCS4351-CZZR CS4392-KZZRCS4352-DZZR  
 CS8421-EZZRCS4351-DZZR CS4361-CZZR

PCN Effective Date:  Lot Effective Date:

Cirrus P/N Change:  Yes  No (Contact the sales representative for availability of samples if applicable)

If yes, provide new part number:

Package Mark Change:  Yes  No

If Yes, briefly explain:

*[Any Fab, Assembly, or Design changes results in pack mark changes, please provide detail]*

- Reason for Change:**
- Design/New Rev
  - Assembly Site
  - Fab Site
  - Other (Specify)
  - Fab Process
  - Additional Assembly Source
  - Assembly Process
  - Additional Fab Source

Carrier Tape and Qty per Reel

- Description of Change:**
- Fix Errata
  - Fix Known Bug
  - Other (specify)
  - Yield Enhancement
  - Performance Improvement

20 TSSOP	ANST Current	ANST New
Vendor	Advantek	Kostat
Qty/Reel	2K	4K

**Quality and Reliability Impact:**

Qualification Data Required?  Yes  No

**Data Sheet Change Required?**  Yes  No

If Yes, briefly explain:

**Software Change Required?**  Yes  No

If Yes, briefly explain:

**Customer Acknowledgement and Agreement**

**Acknowledged and Agreed as of the Date written below:**

Customer Company Name: \_\_\_\_\_

Customer Contact Name: \_\_\_\_\_  
Title: \_\_\_\_\_

Signature: \_\_\_\_\_

Date:

Customer Agreed     Customer Reject     Not Applicable

Customer Comments:

--

	Title: <b>CUSTOMER PROCESS CHANGE NOTIFICATION FORM</b>		
	Digitally Signed By:	Doc No: 4-QUAL-00017	Rev: D

# Qualification Plan

## 2. TSSOP 20

Process	Check item	Sample Size	SPEC
Appearance	Width(mm)	16.03	16.00±0.30
	A0 (mm)	6.87	6.9±0.10
	B0 (mm)	7.00	7.0±0.10
	K0 (mm)	1.50	1.5±0.10
	Material	POLYSTYRENE	POLYSTYRENE
	Drawing	 TSSOP 20LD(Kostat)	

# Qualification Data (Reliability data if necessary)

## Fit analysis report

1. C/TAPE(nor) / PKG'(nor)

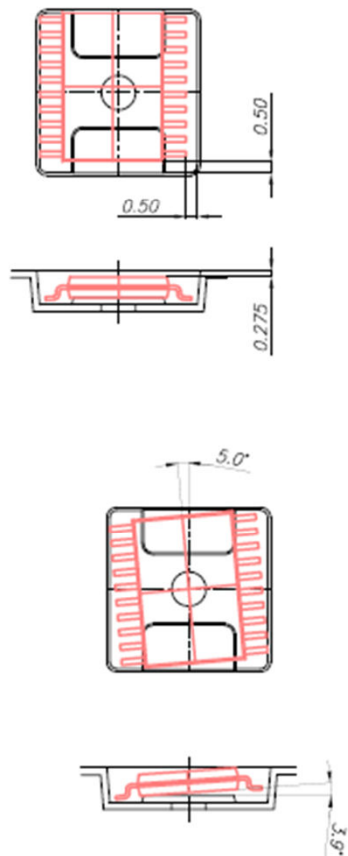

2. C/TAPE(min) / PKG'(max)

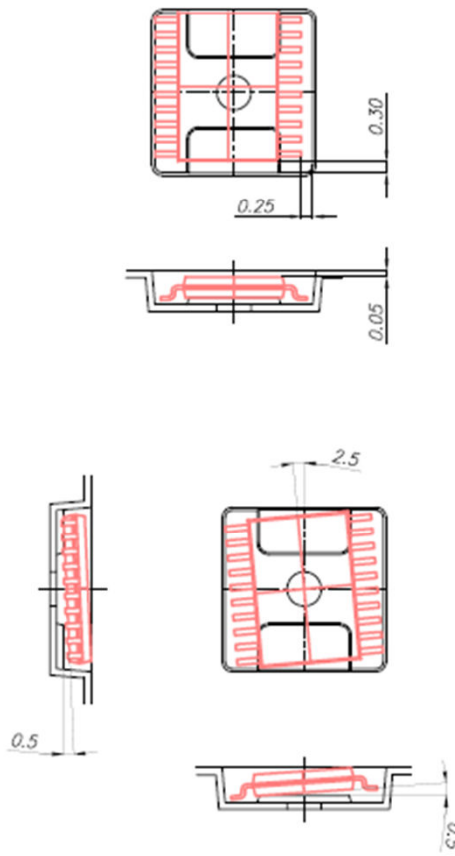

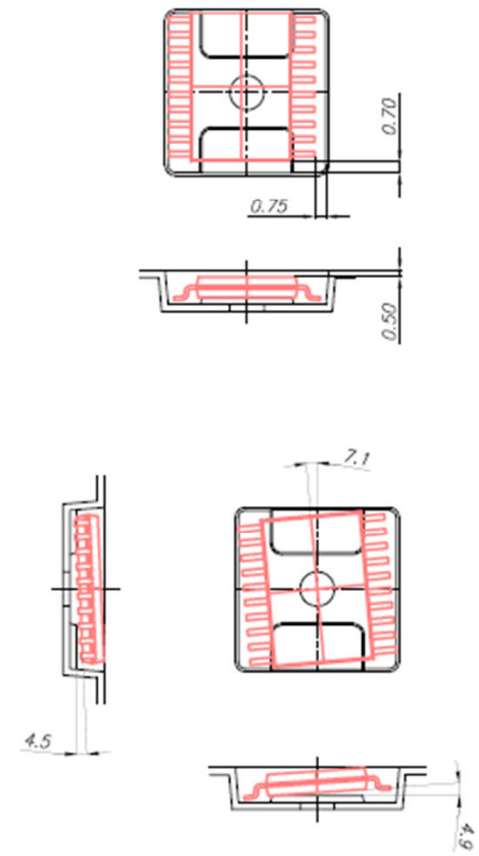

3. C/TAPE(max) / PKG'(min)



# Qualification Data (Reliability data if necessary)

Material drawing comparison:

	Current	Propose
Ao	6.90±0.10	6.90±0.10
Bo	7.00±0.10	7.00±0.10
Ko	1.50±0.10	1.50±0.10
W	16.00±0.30	16.00±0.30
Po	4.00±0.10	4.00±0.10
P1	8.00±0.10	8.00±0.10
P2	2.00±0.10	2.00±0.10
E	1.75±0.10	1.75±0.10
F	7.50±0.10	7.50±0.10
Do	Φ1.5	Φ1.5
D1	Φ1.5	Φ1.5
T	0.3±0.05	0.3±0.05
Drawing	 old	 new

# Qualification Data (Reliability data if necessary)

## QA Data

Vendor's OQA data:



KOSTAT

ANST'S IQA data:



ANST

# Qualification Data (Reliability data if necessary)

## Peel test report

### 4.1. Standard:

4.1.1 Split test: 20g-50g

4.1.2 Full test: 30g-80g

### 4.2. Testing

Sealing time: 30MS

### 4.3.1 Peel test in different temperature.

Temp	Max	Min	Ave	Lo	Hi
160° C	65	48	56.5	30	80
165° C	64	52	58	30	80
170° C	70	43	56.5	30	80

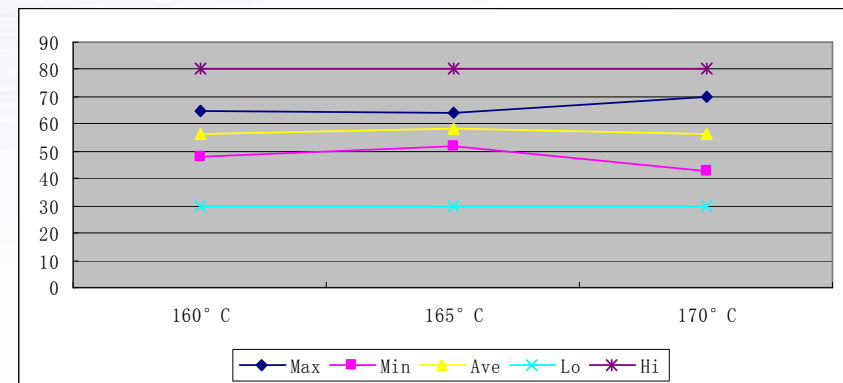

# Qualification Data (Reliability data if necessary)

## Drop test

### 1. Specimen:

Package Code		Package Size	TSSOP/20LD
Lead Count	20 lead	Reel vendor	Advantek
Material Code	3202035372	Sample Size	4K/reel
Packing method	Follow Cirrus's packing method		

# Qualification Data (Reliability data if necessary)

## Drop test

### 2. Test Specification

Sequence	The Parts of the container for free fall drop	Trial
1	The basic corner	1
2	The shortest edge radiating from the container	1
3	The next longest edge radiating from the container	1
4	The longest edge radiating from the container	1
5~10	All six surfaces of the container	6
Total Trials		10
Free Fall Drop Height		1.0 meter

Summary: Zero defect found before and after drop test.

# Qualification Plan

## Cover Tape

Check item		Proposed Cover tape (Denka)	Current Cover tape (Advantek)
Appearance	Length (m)	480	300
	Width (mm)	13.3±0.1	13.3±0.1
	Antistatic polyester film (inch)	0.0007874	0.0010
	Antistatic adhesive coating (inch)	0.00137795	0.00111
	Transparency	OK (Haze:50%)	OK (Haze. 51%)
	Color	Milky white	Natural, non-pigmented
	IQA Report	 IOA report	N/A

# Qualification Data (Reliability data if necessary)

## SGS Report



Carrier tape SGS  
Report



Cover tape SGS  
Report



Carrier tape  
MSDS Report



cover tape MSDS  
Report

# Conclusion

## Conclusion:

1. The new material pass the peel test .
2. The new material pass the IQA dimension test.
- 3.The new material pass the drop test.
- 4.The new vendor's carrier tape and cover tape can meet the request.

# DRAWING REVISION HISTORY

REV. NO.	REASON FOR REV.	DATE	Prepared
AA	New Release	2008/03/05	Mojx
AB	更改标题	2010/05/17	Mojx

<b>ORIGINATOR</b>	Mojx	<b>DEPARTMENT</b>	工艺	
<b>REVIEWER</b>	Zhoujn	<b>DEPARTMENT</b>	工艺	
<b>APPROVER</b>	Lif	<b>DEPARTMENT</b>	测试产品工程部	
<b>APPROVER</b>	Luzf	<b>DEPARTMENT</b>	质量体系控制部	
<b>APPROVER</b>		<b>DEPARTMENT</b>		

<b>UNLESS OTHERWISE SPECIFIED DIMENSIONS ARE IN MILLIMETERS. TOLERANCES ARE:</b>	<b>DECIMALS</b>	<b>ANGLES</b>
XXX X	+0.1	±1°
XXX XX	+0.10	
	+0.050	

<b>PROJECTION</b>	<b>SCALE</b>	<b>SIZE</b>	<b>TITLE</b>
	1:1	A4	 <b>ANST</b> 安盛科技 热带 16mm 6.8mm*6.9mm 395m
<b>DRAWING NO.</b>	<b>Material Code.</b>	<b>Reference Code.</b>	<b>REV.</b>
S-TST-PED-OT-033	3202036175	R0210199X	AB
SHEET			1 OF 2

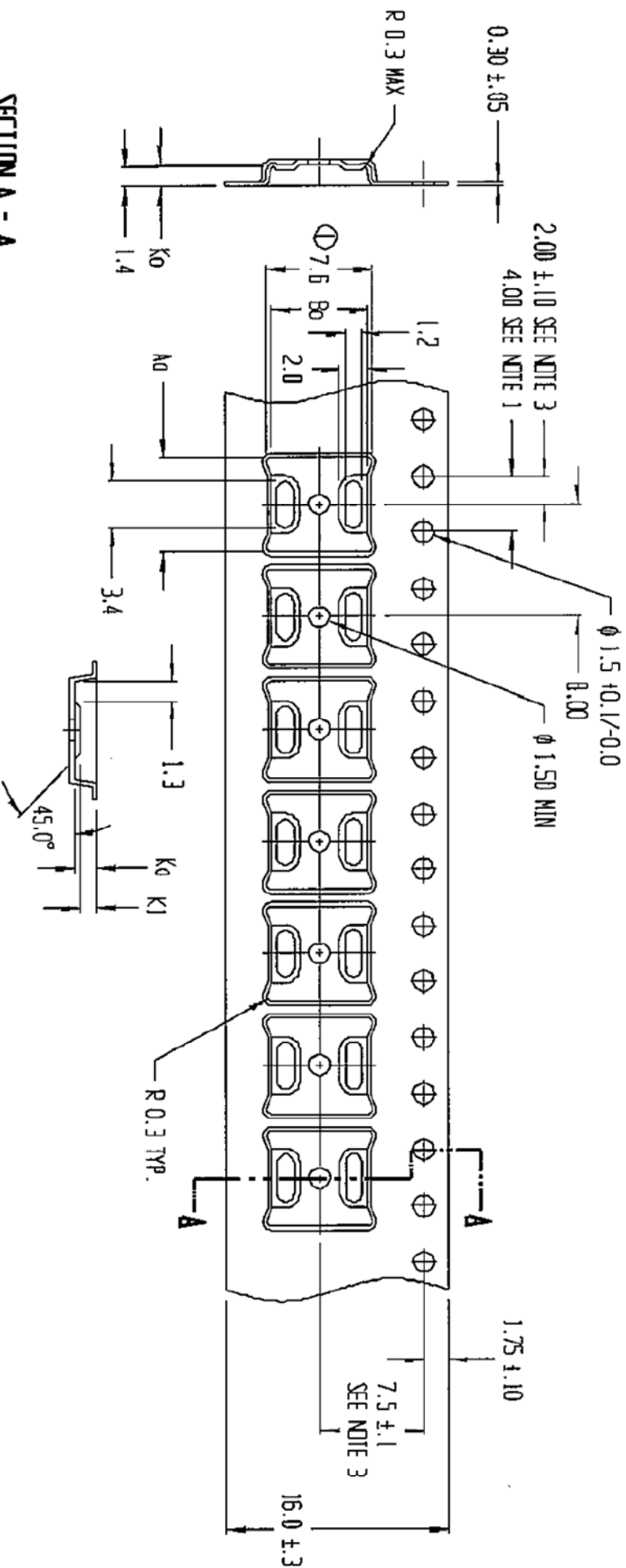

**SECTION A - A**

$A_0 = 6.80$   
 $B_0 = 6.90$   
 $K_0 = 1.50$   
 $K_1 = 1.20$

**NOTES:**



1. JO SPROCKET HOLE PITCH CUMULATIVE TOLERANCE  $\pm 0.2$
2. CAMBER IN COMPLIANCE WITH EIA 481
3. POCKET POSITION RELATIVE TO SPROCKET HOLE MEASURED AS TRUE POSITION OF POCKET, NOT POCKET HOLE

		UNLESS OTHERWISE SPECIFIED, DIMENSIONS ARE IN MILLIMETERS. TOLERANCES ARE:	
		DECIMALS	ANGLES
X.X	±0.1	±1°	
X.X X	±0.10		
X.X XX	±0.050		
PROJECTION	SCALE	SIZE	
		A4	
Reference Code, R021-0199X	Material Code, 3222036175	DRAWING NO., S-1ST-PEID-0T-033	REV., AB
			SHEET 2 OF 2

# DRAWING REVISION HISTORY

REV. NO.	REASON FOR REV.	DATE	Prepared
AA	New Release	2011.03.22	Zhucy

<b>ORIGINATOR</b>	Zhucy	<b>DEPARTMENT</b>	T-PE	 <p><b>Anst</b> 安盛科技</p> <p>UNLESS OTHERWISE SPECIFIED DIMENSIONS ARE IN MILLIMETERS. TOLERANCES ARE: DECIMALS ANGLES XX ±0.2 ±1° XX X ±0.1</p>
<b>REVIEWER</b>	Lif	<b>T-PE</b>		
<b>APPROVER</b>	Luzf	<b>QS/QC</b>		
<b>APPROVER</b>				
<b>APPROVER</b>				

PROJECTION 	SCALE 	SIZE <b>A4</b>
TITLE 胶带 16mm 6.9*7.0mm 305 PS (Kostat)		
DRAWING NO. S-TST-PED-01-070	Material Code. 3202035372	Reference Code.
REV. AA	SHEET 1 OF 2	

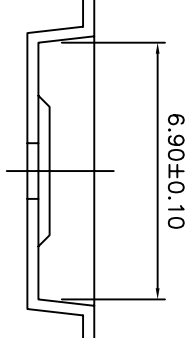
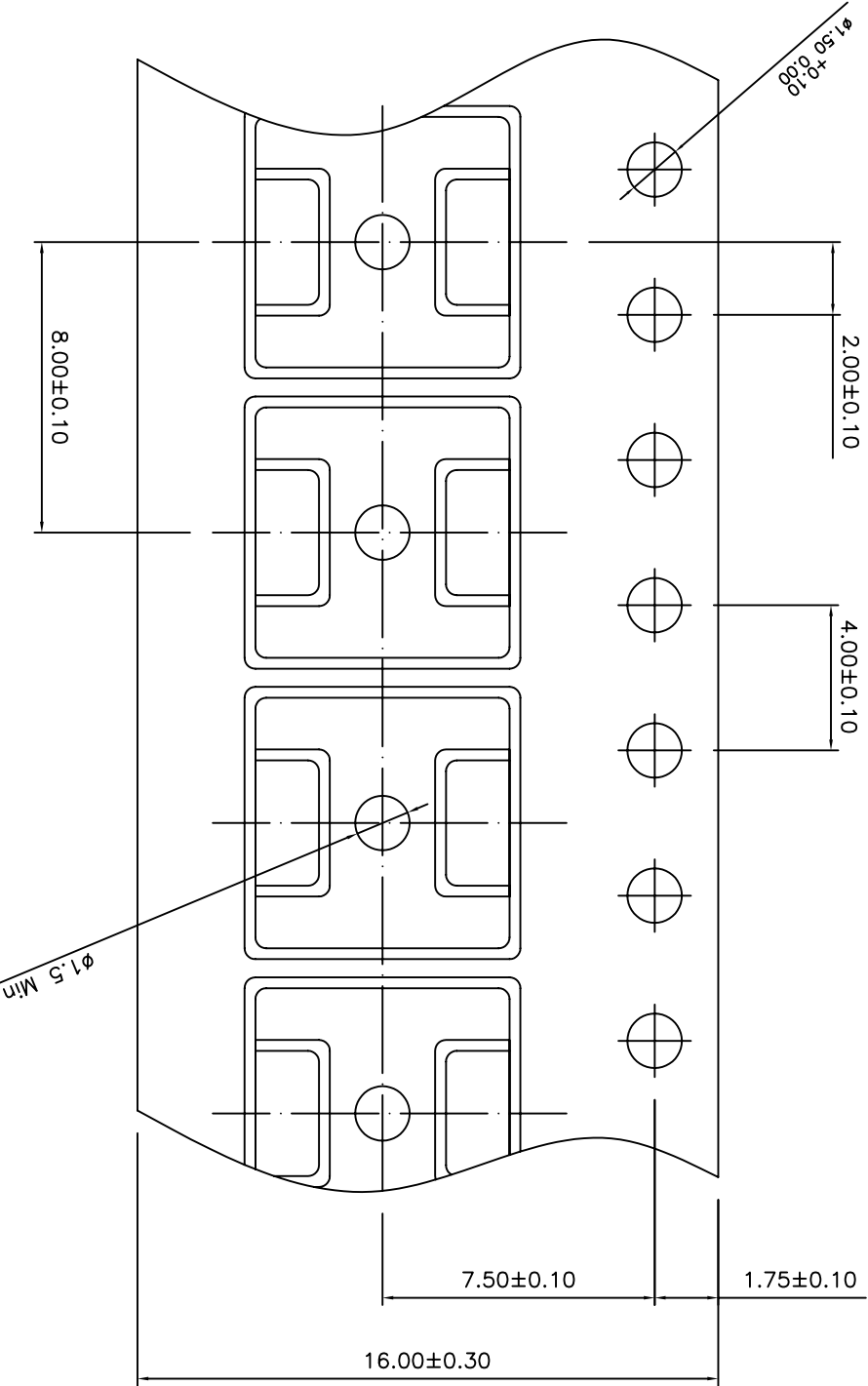
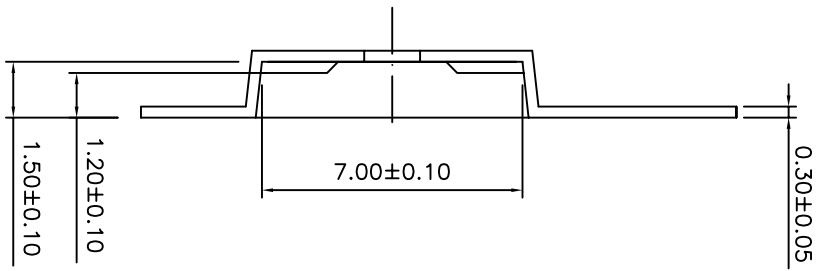

- NOTES:
1. 10 sprocket hole pitch caumulative tolerance ±0.2
  2. Camber not to exceed 1mm in 250mm
  3. Material:Black conductive Polystyrene
  4. Ao and Bo measured on a plane 0.3mm above the bottom of the pocket
  5. Ko measured from a plane on the inside bottom of the pocket to the top surface of the carrier
  6. Pocket position relative to sprocket hole measured as true position of pocket ,not pocket hole.
  7. Pocket center and pocket hole center must be same position



UNLESS OTHERWISE SPECIFIED DIMENSIONS ARE IN MILLIMETERS. TOLERANCES ARE:		TITLE	
DECIMALS	ANGLES	载带 16mm 6.9*7.0mm 305 PS (Kostat)	
XX ±0.13	±1°	DRAWING NO.	
XXX ±0.10		S-1ST-PED-01-070	
PROJECTION	SCALE	Material Code.	SHEET
⊕	A4	3202035372	2 OF 2
	Reference Code.		REV.
			AA

# CARRIER TAPE OUTGOING INSPECTION REPORT

PART NO. : TSSOP 20LD  
 CUSTOMER PART NO. : N/A  
 DRAWING CODE NO. : KS-1608-208  
 MATERIAL : POLYSTYRENE  
 P.O NO. : N/A  
 INVOICE : N/A

CUSTOMER :  
 REVISION NO. :  
 DATE INSP. : 2010.12.06  
 QTY. INSP. : 11 PIECES  
 TOTAL QUANTITY : 1 Rolls  
 LOT NO. :  
 SAMPLE

1. DIMENSIONAL MEASUREMENT :

ITEM	DIMENSION	LSL	USL	1	2	3	4	5	6	7	8	9	10	11	MEAN	STDEV	CPK	P/F
AO	POCKET LENGTH IN AO DIRECTION	6.80	7.00	6.885	6.888	6.889	6.900	6.890	6.892	6.894	6.893	6.896	6.902	6.904	6.894	0.006	5.144	PASS
BO	POCKET LENGTH IN BO DIRECTION	6.90	7.10	6.959	6.963	6.955	6.951	6.963	6.952	6.959	6.955	6.954	6.964	6.960	6.958	0.005	4.266	PASS
E	CENTER OF SPROCKET HOLE TO TAPE EDGE	1.65	1.85	1.781	1.773	1.787	1.774	1.778	1.784	1.772	1.767	1.766	1.768	1.765	1.774	0.008	3.341	PASS
PO	CENTER TO CENTER OF SPROCKET HOLES	3.90	4.10	4.020	3.996	3.996	3.985	4.005	4.005	3.998	4.001	4.003	4.003	4.000	4.001	0.008	3.928	PASS
KO	POCKET DEPTH	1.40	1.60	1.577	1.570	1.562	1.565	1.567	1.568	1.570	1.569	1.560	1.557	1.559	1.566	0.006	1.904	PASS
F	CENTER OF CAVITY HOLES TO (SIDEWAYS)	7.40	7.60	7.500	7.513	7.518	7.503	7.492	7.515	7.519	7.507	7.501	7.518	7.519	7.510	0.010	3.158	PASS
	CENTER OF ROUND SPROCKET HOLES																	
D0	SPROCKET HOLE	1.50	1.60	1.582	1.580	1.583	1.578	1.578	1.571	1.577	1.580	1.577	1.584	1.579	1.579	0.004	2.002	PASS
D1	CENTER HOLES	MIN 1.5		1.643	1.648	1.642	1.649	1.646	1.645	1.643	1.642	1.648	1.641	1.642	1.644	0.003	6.642	PASS
P2	CENTER OF CAVITY HOLES TO (LENGTHWISE)	1.90	2.10	2.026	2.012	2.021	2.021	2.001	2.009	2.022	2.025	2.026	2.022	2.019	2.018	0.008	3.524	PASS
	CENTER OF ROUND SPROCKET HOLES																	
P1	CENTER TO CENTER OF CAVITY HOLES	7.90	8.10	8.000	7.995	8.008	7.999	7.995	8.008	7.996	8.002	7.991	8.006	8.007	8.001	0.006	5.528	PASS
T	TAPE THICKNESS (IS APPLICABLE AS MEASURED AT THE EDGE OF TAPE)	0.25	0.35	0.303	0.317	0.291	0.303	0.300	0.292	0.303	0.298	0.291	0.313	0.304	0.301	0.008	1.923	PASS
W	TAPE WIDTH	15.70	16.30	16.040	16.036	16.033	16.040	16.032	16.039	16.031	16.036	16.043	16.044	16.047	16.038	0.005	16.999	PASS
10XPO	10 SPROCKET PITCH CUMULATIVE VALUE	39.80	40.20	39.976	40.024	39.973	40.019	39.974	40.022	39.983	40.029	39.982	39.976	40.021	39.998	0.024	2.734	PASS

2.0 VISUAL :

DEVECTS	DEFECTS	RESULTS
POCKET DEFECTS	0	ACCEPT
CONTAMINATION	0	ACCEPT
SCRATCH	0	ACCEPT
PIMPLE	< 4/M	ACCEPT
BURRS	0	ACCEPT
OTHERS	0	ACCEPT

3.0 SURFACE RESISTIVITY : 1.0E+04 TO 1.0E+11 OHMS/SQ

4.0 CAMBER : <1MM/250MM, NON-CUMULATIVE OVER 250MM

DIMENSIONAL MEASUREMENT :					
1	2	3	4	5	P/F
0.55	0.35	0.65	0.35	0.55	PASS

5.0 FINAL RESULTS :

A/R ACCEPT

NOTE :

1.0 ALL DIMENSIONS ARE PER EIA-481 AND ARE DISPLAYED IN MILLIMETERS.  
 2.0 T DIMENSION IS MEASURED BY DIGITAL CALIPER, KO IS MEASURED BY DIGITAL HEIGHT GAUGE, OTHERS ARE MEASURED BY PROFILE PROJECTOR

INSPECTED BY : LFYANG DATE : 2010.12.06 APPROVED BY : KS CHOI DATE : 2010.12.06

POSITROL LOG

Production Line: ALL		Process: IQA		Document No.: S-TCM-IQA-PL-01		Revision: AE	
Title: <u>新带</u> Incoming Inspection Report		Frequency: 1X/Shipment		Revise Date: 08.10.30			
Receive Date: 2010.12.10		Supplier Name: <u># 1117瑞</u>		Eng'r Approval			
Inspection Date: 2010.12.10		IQA No.:		CT-DK-10-L-018-Q		黄菲	
Material Code: 202035175		Material Type:		TS40P20LD		<input checked="" type="checkbox"/> Accept <input type="checkbox"/> Reject	
<b>1. Verification</b>							
Packing Condition: <input checked="" type="checkbox"/> OK <input type="checkbox"/> NG		Quantity:		1 ROLLS			
Lot No.:		CJ20101203139030011					
<b>2. C of C</b> <input checked="" type="checkbox"/> Accept <input type="checkbox"/> Reject							
Material Type: TS40P20LD		Material Code:		N/A		Q'ty: 1 ROLLS	
Drawing No./Rev.:		KS-1608-208		Mfg. Date:		N/A	
Lot No.:		N/A		Dimension Test Result:		<input checked="" type="checkbox"/> OK <input type="checkbox"/> NG <input type="checkbox"/> NA	
Visual Inspection Result:		<input checked="" type="checkbox"/> OK <input type="checkbox"/> NG		Function Test Result:		<input type="checkbox"/> OK <input type="checkbox"/> NG <input checked="" type="checkbox"/> NA	
<b>3. Label</b> <input checked="" type="checkbox"/> Accept <input type="checkbox"/> Reject							
Material Type: TS40P20LD		Mfg. Date:		N/A		Q'ty: <input checked="" type="checkbox"/> OK <input type="checkbox"/> NG	
Material Code: N/A		Expired Date:		N/A		Lot No.: <input checked="" type="checkbox"/> OK <input type="checkbox"/> NG	
Supplier Name:		<input checked="" type="checkbox"/> OK <input type="checkbox"/> NG					
<b>4. Inspection items</b> <input checked="" type="checkbox"/> Accept <input type="checkbox"/> Reject							
S/N	Item	Sample Size: (Ac=0, Re=1)	Defect Q'ty	Defect Mode	Result		
1	外观	1	0	N/A	<input checked="" type="checkbox"/> OK <input type="checkbox"/> NG		
2	尺寸	1	0	N/A	<input type="checkbox"/> OK <input type="checkbox"/> NG		
3	表面涂层	1	0	N/A	<input checked="" type="checkbox"/> OK <input type="checkbox"/> NG		
4					<input type="checkbox"/> OK <input type="checkbox"/> NG		
5					<input type="checkbox"/> OK <input type="checkbox"/> NG		
6					<input type="checkbox"/> OK <input type="checkbox"/> NG		
<b>5. XRF Test</b> <input checked="" type="checkbox"/> Accept <input type="checkbox"/> Reject <input type="checkbox"/> NA							
S/N	Element 元素	Curve 曲线	Upper Limit 上限规格 (ppm)	Content 含量 (ppm)	Result 结果		
1	Hg 汞	<input checked="" type="checkbox"/> PE <input type="checkbox"/> SOLDER	ND	ND	<input checked="" type="checkbox"/> OK <input type="checkbox"/> NG		
2	Br 溴	PE	1000	ND	<input checked="" type="checkbox"/> OK <input type="checkbox"/> NG <input type="checkbox"/> NA		
3	Cd 镉	<input checked="" type="checkbox"/> PE <input type="checkbox"/> SOLDER	5	4.6	<input checked="" type="checkbox"/> OK <input type="checkbox"/> NG		
4	Pb 铅	<input checked="" type="checkbox"/> PE <input type="checkbox"/> SOLDER	100	19.5	<input checked="" type="checkbox"/> OK <input type="checkbox"/> NG		
5	Cr 铬	<input checked="" type="checkbox"/> workCurveCr <input type="checkbox"/> SOLDER	100	ND	<input checked="" type="checkbox"/> OK <input type="checkbox"/> NG		
6	Cr+Cd+Pb+Hg	NA	100	26.1	<input checked="" type="checkbox"/> OK <input type="checkbox"/> NG <input type="checkbox"/> NA		
<b>6. Final Result</b>							
Final Result		<input checked="" type="checkbox"/> Accept <input type="checkbox"/> Reject		Stamp			
Remark:							

# POSITROL LOG

Production Line: ALL		Process: IQA	Document No.: S-TCM-IQA-PL-01	Revision: AE
Title: <u>盖带</u> Incoming Inspection Report		Frequency: 1X/Shipment		Revise Date: 08.10.30
Receive Date	<u>2010.3.11</u>	Supplier Name	<u>芯玮</u>	Eng'r Approval 
Inspection Date	<u>2010.3.14</u>	IQA No.	<u>CO-XX-10-07-08-Q</u>	
Material Code	<u>N/A</u>	Material Type	<u>盖带 13.3mm 480M</u>	

**1. Verification**

Packing Condition	<input checked="" type="checkbox"/> OK <input type="checkbox"/> NG	Quantity	<u>1</u>
Lot No.	<u>  /  </u>	<input checked="" type="checkbox"/> Accept <input type="checkbox"/> Reject	

**2. C of C**

Material Type	<u>13.3MM-480M</u>	Material Code	<u>N/A</u>	Q'ty	<u>1</u>
Drawing No./Rev.	<u>N/A</u>	Mfg. Date	<u>N/A</u>	Expired Date	<u>N/A</u>
Lot No.	<u>N/A</u>	Dimension Test Result	<input checked="" type="checkbox"/> OK <input type="checkbox"/> NG <input type="checkbox"/> NA		
Visual Inspection Result	<input checked="" type="checkbox"/> OK <input type="checkbox"/> NG	Function Test Result	<input type="checkbox"/> OK <input type="checkbox"/> NG <input checked="" type="checkbox"/> NA		

**3. Label**

Material Type	<del>  /  </del>		Mfg. Date	<del>  /  </del>		Q'ty	<input type="checkbox"/> OK <input type="checkbox"/> NG
Material Code	<del>  /  </del>		Expired Date	<del>  /  </del>		Lot No.	<input type="checkbox"/> OK <input type="checkbox"/> NG
Supplier Name	<input type="checkbox"/> OK <input type="checkbox"/> NG						<input checked="" type="checkbox"/> Accept <input type="checkbox"/> Reject

**4. Inspection items**

S/N	Item	Sample Size: (Ac=0, Re=1)	Defect Q'ty	Defect Mode	Result
1	<u>外观</u>	<u>1</u>	<u>0</u>	<u>N/A</u>	<input checked="" type="checkbox"/> OK <input type="checkbox"/> NG
2	<u>表面电阻</u>	<u>1</u>	<u>0</u>	<u>N/A</u>	<input checked="" type="checkbox"/> OK <input type="checkbox"/> NG
3					<input type="checkbox"/> OK <input type="checkbox"/> NG
4					<input type="checkbox"/> OK <input type="checkbox"/> NG
5					<input type="checkbox"/> OK <input type="checkbox"/> NG
6					<input checked="" type="checkbox"/> Accept <input type="checkbox"/> Reject <input type="checkbox"/> NA

**5. XRF Test**

S/N	Element 元素	Curve 曲线	Upper Limit 上限规格 (ppm)	Content 含量 (ppm)	Result 结果
1	Hg 汞	<input checked="" type="checkbox"/> PE <input type="checkbox"/> SOLDER	ND	<u>ND</u>	<input checked="" type="checkbox"/> OK <input type="checkbox"/> NG
2	Br 溴	PE	1000	<u>ND</u>	<input checked="" type="checkbox"/> OK <input type="checkbox"/> NG <input type="checkbox"/> NA
3	Cd 镉	<input checked="" type="checkbox"/> PE <input type="checkbox"/> SOLDER	5	<u>ND</u>	<input checked="" type="checkbox"/> OK <input type="checkbox"/> NG
4	Pb 铅	<input checked="" type="checkbox"/> PE <input type="checkbox"/> SOLDER	100	<u>30.4</u>	<input checked="" type="checkbox"/> OK <input type="checkbox"/> NG
5	Cr 铬	<input checked="" type="checkbox"/> workCurveCr <input type="checkbox"/> SOLDER	100	<u>ND</u>	<input checked="" type="checkbox"/> OK <input type="checkbox"/> NG
6	Cr+Cd+Pb+Hg	NA	100	<u>30.4</u>	<input checked="" type="checkbox"/> OK <input type="checkbox"/> NG <input type="checkbox"/> NA

**6. Final Result**

Final Result	<input checked="" type="checkbox"/> Accept <input type="checkbox"/> Reject	Stamp	
--------------	--	-------	--

Remark:



# DRAWING REVISION HISTORY

REV. NO.	REASON FOR REV.	DATE	Prepared
AA	New Release	2011.03.22	Zhucy

	<b>Anst</b> 安盛科技			
ORIGINATOR	NAME	DEPARTMENT	TITLE	
	Zhucy	T-PE	裁带 16mm 6.9*7.0mm 305 PS (Kostat)	
REVIEWER	Lif	T-PE	DRAWING NO. S-IST-PEE-0T-070	
APPROVER	Luzf	QS/QC	REV. AA	
APPROVER			Material Code. 320205372	
APPROVER			Reference Code.	
			UNLESS OTHERWISE SPECIFIED DIMENSIONS ARE IN MILLIMETERS. TOLERANCES ARE:	SIZE A4
			DECIMALS ANGLES	PROJECTION
			XX ±0.2 ±1°	SCALE 1:1
			XX X ±0.1	

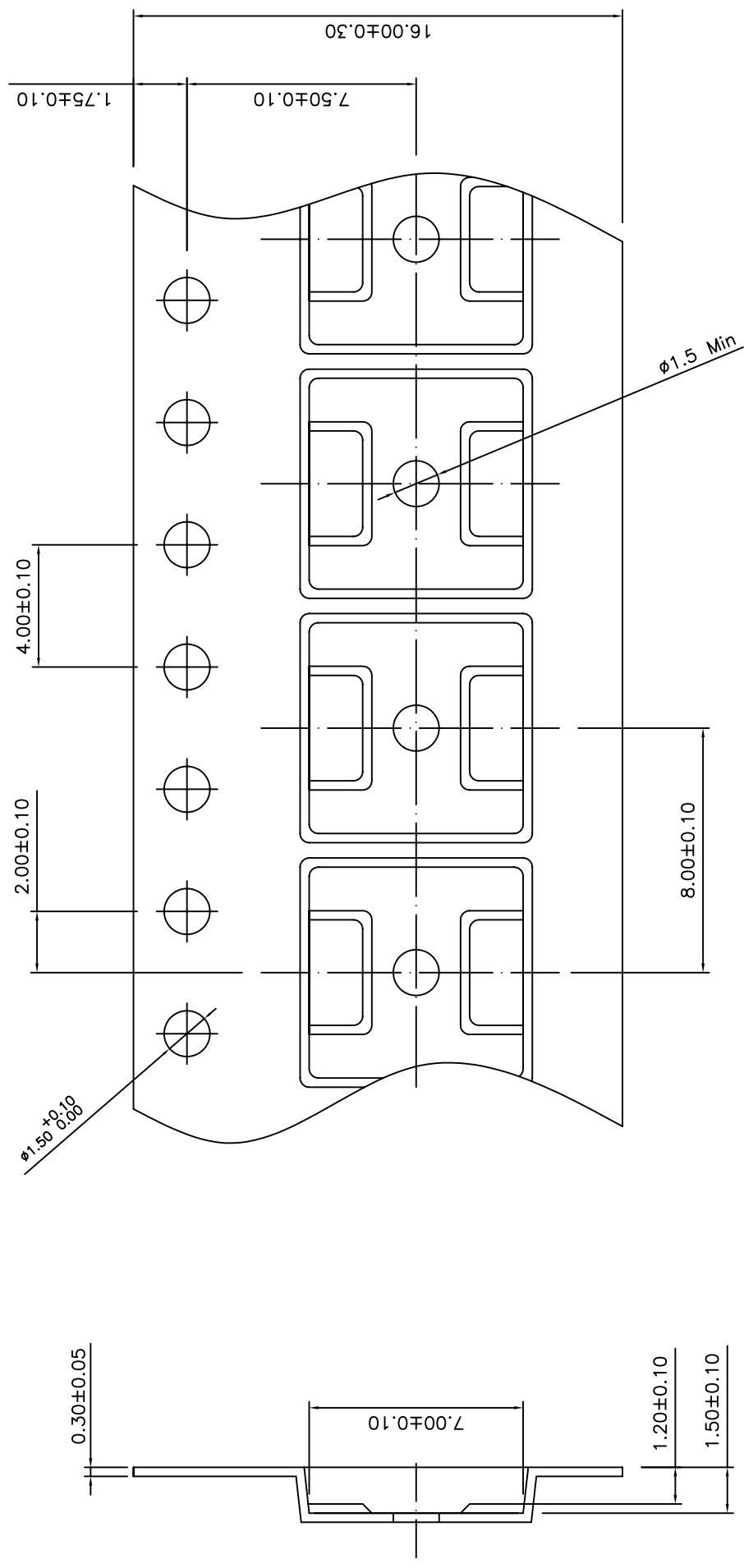

- NOTES:
1. 10 sprocket hole pitch caumulative tolerance  $\pm 0.2$
  2. Camber not to exceed 1mm in 250mm
  3. Material: Black conductive Polystyrene
  4. A<sub>o</sub> and B<sub>o</sub> measured on a plane 0.3mm above the bottom of the pocket
  5. K<sub>o</sub> measured from a plane on the inside bottom of the pocket to the top surface of the carrier
  6. Pocket position relative to sprocket hole measured as true position of pocket ,not pocket hole.
  7. Pocket center and pocket hole center must be same position

<b>Anst</b> 安盛科技	
TITLE 载带 16mm 6.9*7.0mm 305 PS (Kostat)	
UNLESS OTHERWISE SPECIFIED DIMENSIONS ARE IN MILLIMETERS. TOLERANCES ARE: DECIMALS ANGLES XX ±0.13 ±1° XX X ±0.10	DRAWING NO. S-TST-PED-0T-070
PROJECTION SCALE	REV. AA
SIZE A4	SHEET 2 OF 2
Material Code. 3202035372	Reference Code.



**Test Report No. F690501/LF-CTSAYAA10-12126**

Issued Date: April 09, 2010

Page 1 of 6

To: **KOSTAT INC**  
1 Complex(102-dong/6f), Buchon Techno-park  
364, Samjung-dong, Ojung-ku  
Buchon-city  
GYEONGGI-DO 421-809  
Korea

The following merchandise was submitted and identified by the client as :

**SGS File No.** : AYAA10-12126  
**Product Name** : PS Black Sheet for embossed\_Punched Carrier Tape  
**Item No./Part No.** : Carrier Tape(Black sheet)  
**Received Date** : April 02, 2010  
**Test Performing Date** : April 05, 2010  
**Test Performed** : SGS Testing Korea tested the sample(s) selected by applicant with following results  
**Test Results** : For further details, please refer to following page(s)

**SGS Testing Korea Co. Ltd.**

**Jeff Jang / Chemical Lab Mgr**

**Pluto Kim**  
**Cindy Park/ Testing Person**

**Test Report No. F690501/LF-CTSAYAA10-12126**

Issued Date: April 09, 2010

Page 2 of 6

**Sample No.** : AYAA10-12126.001  
**Sample Description** : PS Black Sheet for embossed\_Punched Carrier Tape  
**Item No./Part No.** : Carrier Tape(Black sheet)

**Heavy Metals**

Test Items	Unit	Test Method	MDL	Results
Cadmium (Cd)	mg/kg	With reference to IEC 62321:2008, ICP	0.5	N.D.
Lead (Pb)	mg/kg	With reference to IEC 62321:2008, ICP	5	N.D.
Mercury (Hg)	mg/kg	With reference to IEC 62321:2008, ICP	2	N.D.
Hexavalent Chromium (Cr VI)	mg/kg	With reference to IEC 62321:2008, UV-VIS	1	N.D.
Antimony (Sb)	mg/kg	With reference to EPA 3050B(1996), US EPA 6010B(1996), ICP	10	N.D.

**Flame Retardants-PBBs/PBDEs**

Test Items	Unit	Test Method	MDL	Results
Monobromobiphenyl	mg/kg	With reference to IEC 62321:2008, GC-MS	5	N.D.
Dibromobiphenyl	mg/kg	With reference to IEC 62321:2008, GC-MS	5	N.D.
Tribromobiphenyl	mg/kg	With reference to IEC 62321:2008, GC-MS	5	N.D.
Tetrabromobiphenyl	mg/kg	With reference to IEC 62321:2008, GC-MS	5	N.D.
Pentabromobiphenyl	mg/kg	With reference to IEC 62321:2008, GC-MS	5	N.D.
Hexabromobiphenyl	mg/kg	With reference to IEC 62321:2008, GC-MS	5	N.D.
Heptabromobiphenyl	mg/kg	With reference to IEC 62321:2008, GC-MS	5	N.D.
Octabromobiphenyl	mg/kg	With reference to IEC 62321:2008, GC-MS	5	N.D.
Nonabromobiphenyl	mg/kg	With reference to IEC 62321:2008, GC-MS	5	N.D.
Decabromobiphenyl	mg/kg	With reference to IEC 62321:2008, GC-MS	5	N.D.
Monobromodiphenyl ether	mg/kg	With reference to IEC 62321:2008, GC-MS	5	N.D.
Dibromodiphenyl ether	mg/kg	With reference to IEC 62321:2008, GC-MS	5	N.D.
Tribromodiphenyl ether	mg/kg	With reference to IEC 62321:2008, GC-MS	5	N.D.
Tetrabromodiphenyl ether	mg/kg	With reference to IEC 62321:2008, GC-MS	5	N.D.
Pentabromodiphenyl ether	mg/kg	With reference to IEC 62321:2008, GC-MS	5	N.D.
Hexabromodiphenyl ether	mg/kg	With reference to IEC 62321:2008, GC-MS	5	N.D.
Heptabromodiphenyl ether	mg/kg	With reference to IEC 62321:2008, GC-MS	5	N.D.
Octabromodiphenyl ether	mg/kg	With reference to IEC 62321:2008, GC-MS	5	N.D.
Nonabromodiphenyl ether	mg/kg	With reference to IEC 62321:2008, GC-MS	5	N.D.

NOTE: (1) N.D. = Not detected.(&lt;MDL)

(2) mg/kg = ppm

(3) MDL = Method Detection Limit

(4) - = No regulation

(5) \*\* = Qualitative analysis (No Unit)

(6) \* = Boiling-water-extraction:

Negative = Absence of CrVI coating

Positive = Presence of CrVI coating; the detected concentration in boiling-water-extraction solution is equal or greater than 0.02 mg/kg with 50 cm<sup>2</sup> sample surface area.

This document is issued by the Company subject to its General Conditions of Service printed overleaf, available on request or accessible at [www.sgs.com/terms\\_and\\_conditions.htm](http://www.sgs.com/terms_and_conditions.htm) and, for electronic format documents, subject to Terms and Conditions for Electronic Documents at [www.sgs.com/terms\\_e-document.htm](http://www.sgs.com/terms_e-document.htm). Attention is drawn to the limitation of liability, indemnification and jurisdiction issues defined therein. Any holder of this document is advised that information contained herein reflects the Company's findings at the time of its intervention only and within the limits of Client's instructions, if any. The Company's sole responsibility is to its Client and this document does not exonerate parties to a transaction from exercising all their rights and obligations under the transaction documents. This document cannot be reproduced except in full, without prior written approval of the Company. Any unauthorized alteration, forgery or falsification of the content or appearance of this document is unlawful and offenders may be prosecuted to the fullest extent of the law.  
Unless otherwise stated the results shown in this test report refer only to the sample(s) tested and such sample(s) are retained for 180 days only.



# Test Report No. F690501/LF-CTSAYAA10-12126

Issued Date: April 09, 2010

Page 3 of 6

Sample No. : AYAA10-12126.001  
Sample Description : PS Black Sheet for embossed\_Punched Carrier Tape  
Item No./Part No. : Carrier Tape(Black sheet)

## Flame Retardants-PBBs/PBDEs

Test Items	Unit	Test Method	MDL	Results
Decabromodiphenyl ether	mg/kg	With reference to IEC 62321:2008, GC-MS	5	N.D.

## Phthalates

Test Items	Unit	Test Method	MDL	Results
Di-(2-ethylhexyl) phthalate (DEHP)	mg/kg	US EPA 8061A , GC/MS	50	N.D.
Benzyl butyl phthalate (BBP)	mg/kg	US EPA 8061A , GC/MS	50	N.D.
Dibutyl phthalate (DBP)	mg/kg	US EPA 8061A , GC/MS	50	N.D.

## Halogen Contents

Test Items	Unit	Test Method	MDL	Results
Bromine(Br)	mg/kg	With reference to ASTM D 7359-08 , IC	30	N.D.
Chlorine(Cl)	mg/kg	With reference to ASTM D 7359-08 , IC	30	N.D.

## Flame Retardants

Test Items	Unit	Test Method	MDL	Results
Hexabromocyclododecane	mg/kg	USEPA 3540C, LC/MS	5	N.D.

## Other(s)

Test Items	Unit	Test Method	MDL	Results
PFOS(Perfluorooctane Sulfonates-Acid/Metal Salt/Amide)	mg/kg	US EPA 3540C/3550C, LC/MS	1	N.D.

- NOTE:
- (1) N.D. = Not detected.(<MDL)
  - (2) mg/kg = ppm
  - (3) MDL = Method Detection Limit
  - (4) - = No regulation
  - (5) \*\* = Qualitative analysis (No Unit)
  - (6) \* = Boiling-water-extraction:
    - Negative = Absence of CrVI coating
    - Positive = Presence of CrVI coating; the detected concentration in boiling-water-extraction solution is equal or greater than 0.02 mg/kg with 50 cm<sup>2</sup> sample surface area.

This document is issued by the Company subject to its General Conditions of Service printed overleaf, available on request or accessible at [www.sgs.com/terms\\_and\\_conditions.htm](http://www.sgs.com/terms_and_conditions.htm) and, for electronic format documents, subject to Terms and Conditions for Electronic Documents at [www.sgs.com/terms\\_e-document.htm](http://www.sgs.com/terms_e-document.htm). Attention is drawn to the limitation of liability, indemnification and jurisdiction issues defined therein. Any holder of this document is advised that information contained herein reflects the Company's findings at the time of its intervention only and within the limits of Client's instructions, if any. The Company's sole responsibility is to its Client and this document does not exonerate parties to a transaction from exercising all their rights and obligations under the transaction documents. This document cannot be reproduced except in full, without prior written approval of the Company. Any unauthorized alteration, forgery or falsification of the content or appearance of this document is unlawful and offenders may be prosecuted to the fullest extent of the law.  
Unless otherwise stated the results shown in this test report refer only to the sample(s) tested and such sample(s) are retained for 180 days only.

**Picture of Sample as Received:**

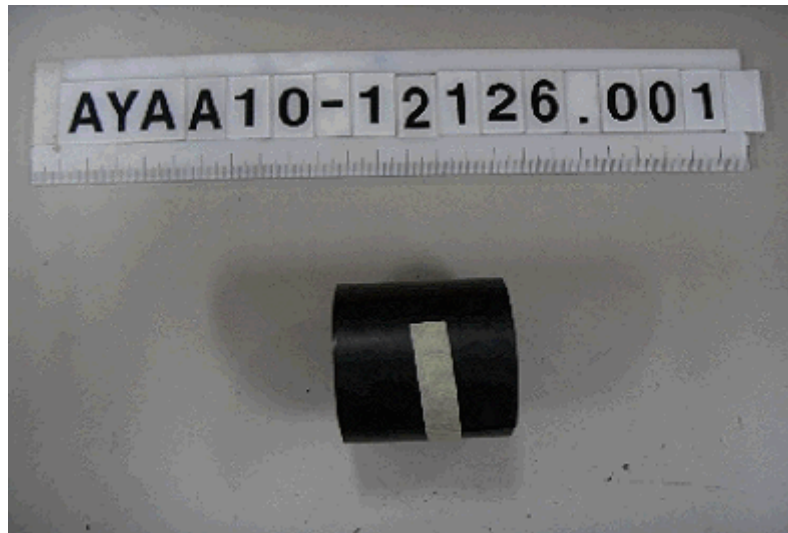

- NOTE:
- (1) N.D. = Not detected.(<MDL)
  - (2) mg/kg = ppm
  - (3) MDL = Method Detection Limit
  - (4) - = No regulation
  - (5) \*\* = Qualitative analysis (No Unit)
  - (6) \* = Boiling-water-extraction:  
 Negative = Absence of CrVI coating  
 Positive = Presence of CrVI coating; the detected concentration in boiling-water-extraction solution is equal or greater than 0.02 mg/kg with 50 cm<sup>2</sup> sample surface area.

This document is issued by the Company subject to its General Conditions of Service printed overleaf, available on request or accessible at [www.sgs.com/terms\\_and\\_conditions.htm](http://www.sgs.com/terms_and_conditions.htm) and, for electronic format documents, subject to Terms and Conditions for Electronic Documents at [www.sgs.com/terms\\_e-document.htm](http://www.sgs.com/terms_e-document.htm). Attention is drawn to the limitation of liability, indemnification and jurisdiction issues defined therein. Any holder of this document is advised that information contained herein reflects the Company's findings at the time of its intervention only and within the limits of Client's instructions, if any. The Company's sole responsibility is to its Client and this document does not exonerate parties to a transaction from exercising all their rights and obligations under the transaction documents. This document cannot be reproduced except in full, without prior written approval of the Company. Any unauthorized alteration, forgery or falsification of the content or appearance of this document is unlawful and offenders may be prosecuted to the fullest extent of the law.  
 Unless otherwise stated the results shown in this test report refer only to the sample(s) tested and such sample(s) are retained for 180 days only.

**Testing Flow Chart for RoHS: Cd/Pb/Hg/Cr<sup>6+</sup>/PBBs&PBDEs Testing**

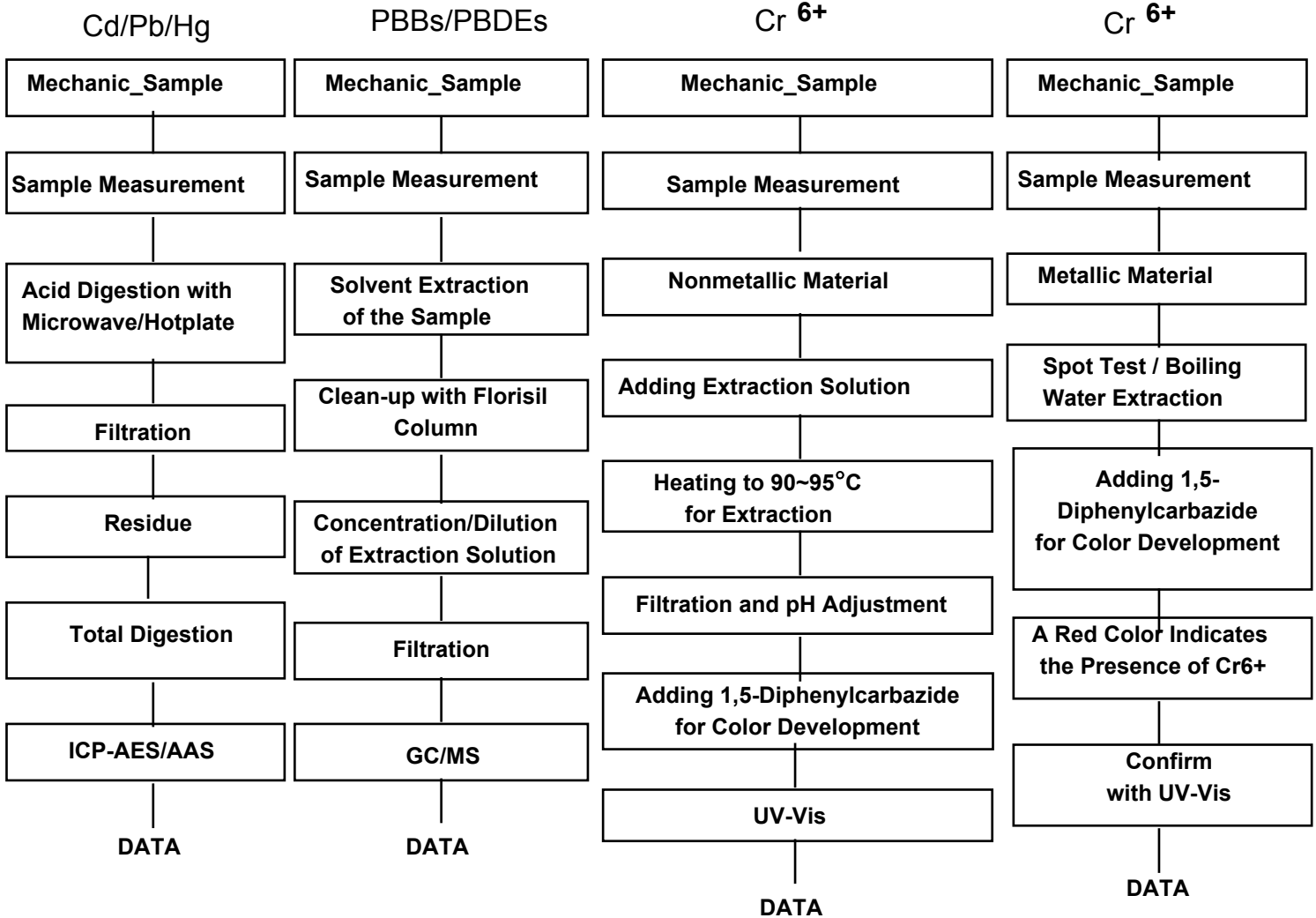

The samples were dissolved totally by pre-conditioning method according to above flow chart for Cd,Pb,Hg.

Operator Dami Yeom

Section Chief Jeff Jang

- NOTE:
- (1) N.D. = Not detected.(<MDL)
  - (2) mg/kg = ppm
  - (3) MDL = Method Detection Limit
  - (4) - = No regulation
  - (5) \*\* = Qualitative analysis (No Unit)
  - (6) \* = Boiling-water-extraction:  
 Negative = Absence of CrVI coating  
 Positive = Presence of CrVI coating; the detected concentration in boiling-water-extraction solution is equal or greater than 0.02 mg/kg with 50 cm<sup>2</sup> sample surface area.

This document is issued by the Company subject to its General Conditions of Service printed overleaf, available on request or accessible at [www.sgs.com/terms\\_and\\_conditions.htm](http://www.sgs.com/terms_and_conditions.htm) and, for electronic format documents, subject to Terms and Conditions for Electronic Documents at [www.sgs.com/terms\\_e-document.htm](http://www.sgs.com/terms_e-document.htm). Attention is drawn to the limitation of liability, indemnification and jurisdiction issues defined therein. Any holder of this document is advised that information contained herein reflects the Company's findings at the time of its intervention only and within the limits of Client's instructions, if any. The Company's sole responsibility is to its Client and this document does not exonerate parties to a transaction from exercising all their rights and obligations under the transaction documents. This document cannot be reproduced except in full, without prior written approval of the Company. Any unauthorized alteration, forgery or falsification of the content or appearance of this document is unlawful and offenders may be prosecuted to the fullest extent of the law. Unless otherwise stated the results shown in this test report refer only to the sample(s) tested and such sample(s) are retained for 180 days only.



### Flow Chart for Halogen Test

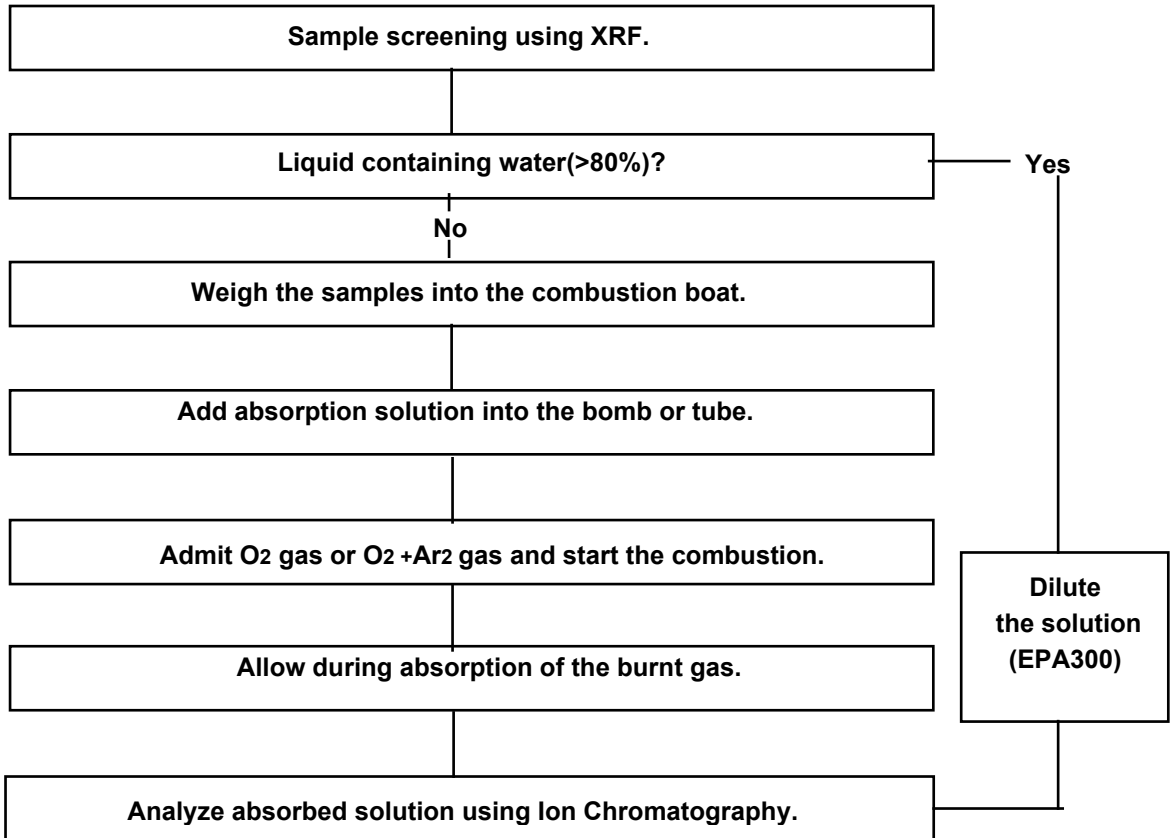

\*\*\* End \*\*\*

- NOTE:
- (1) N.D. = Not detected.(<MDL)
  - (2) mg/kg = ppm
  - (3) MDL = Method Detection Limit
  - (4) - = No regulation
  - (5) \*\* = Qualitative analysis (No Unit)
  - (6) \* = Boiling-water-extraction:  
 Negative = Absence of CrVI coating  
 Positive = Presence of CrVI coating; the detected concentration in boiling-water-extraction solution is equal or greater than 0.02 mg/kg with 50 cm2 sample surface area.

This document is issued by the Company subject to its General Conditions of Service printed overleaf, available on request or accessible at [www.sgs.com/terms\\_and\\_conditions.htm](http://www.sgs.com/terms_and_conditions.htm) and, for electronic format documents, subject to Terms and Conditions for Electronic Documents at [www.sgs.com/terms\\_e-document.htm](http://www.sgs.com/terms_e-document.htm). Attention is drawn to the limitation of liability, indemnification and jurisdiction issues defined therein. Any holder of this document is advised that information contained herein reflects the Company's findings at the time of its intervention only and within the limits of Client's instructions, if any. The Company's sole responsibility is to its Client and this document does not exonerate parties to a transaction from exercising all their rights and obligations under the transaction documents. This document cannot be reproduced except in full, without prior written approval of the Company. Any unauthorized alteration, forgery or falsification of the content or appearance of this document is unlawful and offenders may be prosecuted to the fullest extent of the law. Unless otherwise stated the results shown in this test report refer only to the sample(s) tested and such sample(s) are retained for 180 days only.

## Test Report

No. SHAEC1007136603

Date: 31 May 2010

Page 1 of 11

DENKI KAGAKU KOGYO KABUSHIKI KAISHA

NIHONBISHI MITSUI TOWER, 1-1, NIHONBASHI-MUROMACHI 2-CHOME, CHUO-KU, TOKYO, JAPAN

The following sample(s) was/were submitted and identified on behalf of the clients as : COVER TAPE

SGS Job No. : SP10-017729 - SH  
Model No. : ALS-PRA  
Date of Sample Received : 26 May 2010  
Testing Period : 26 May 2010 - 31 May 2010  
Test Requested : Selected test(s) as requested by client.  
Test Method : Please refer to next page(s).  
Test Results : Please refer to next page(s).  
Conclusion : Based on the performed tests on submitted samples, the results comply with the RoHS Directive 2002/95/EC and its subsequent amendments.

Signed for and on behalf of  
SGS-CSTC Ltd.



Fan Jingjie, JJ  
Approved Signatory

This document is issued by the Company under its General Conditions of Service printed overleaf or available on request and accessible at [http://www.sgs.com/terms\\_and\\_conditions.htm](http://www.sgs.com/terms_and_conditions.htm). Attention is drawn to the limitation of liability, indemnification and jurisdiction issues defined therein. Any holder of this document is advised that information contained hereon reflects the Company's findings at the time of its intervention only and within the limits of Client's instructions, if any. The Company's sole responsibility is to its Client and this document does not exonerate parties to a transaction from exercising all their rights and obligations under the transaction documents. Any unauthorized alteration, forgery or falsification of the content or appearance of this document is unlawful and offenders may be prosecuted to the fullest extent of the law. Unless otherwise stated the results shown in this test report refer only to the sample(s) tested. This document cannot be reproduced except in full, without prior approval of the Company.

Test Results :

Test Part Description :

Specimen No.	SGS Sample ID	Description
1	SHA10-071366.002	Transparent plastic tape

Remarks :

- (1) 1 mg/kg = 1 ppm = 0.0001%
- (2) MDL = Method Detection Limit
- (3) ND = Not Detected ( < MDL )
- (4) "-" = Not Regulated

RoHS Directive 2002/95/EC

Test Method : With reference to IEC 62321:2008

- (1) Determination of Cadmium by ICP-OES.
- (2) Determination of Lead by ICP-OES.
- (3) Determination of Mercury by ICP-OES.
- (4) Determination of Hexavalent Chromium by Colorimetric Method using UV-Vis.
- (5) Determination of PBBs / PBDEs content by GC-MS.

Test Item(s)	Limit	Unit	MDL	002
Cadmium (Cd)	100	mg/kg	2	ND
Lead (Pb)	1,000	mg/kg	2	ND
Mercury (Hg)	1,000	mg/kg	2	ND
Hexavalent Chromium (CrVI)	1,000	mg/kg	2	ND
Sum of PBBs	1,000	mg/kg	-	ND
Monobromobiphenyl	-	mg/kg	5	ND
Dibromobiphenyl	-	mg/kg	5	ND
Tribromobiphenyl	-	mg/kg	5	ND
Tetrabromobiphenyl	-	mg/kg	5	ND
Pentabromobiphenyl	-	mg/kg	5	ND
Hexabromobiphenyl	-	mg/kg	5	ND
Heptabromobiphenyl	-	mg/kg	5	ND
Octabromobiphenyl	-	mg/kg	5	ND
Nonabromobiphenyl	-	mg/kg	5	ND
Decabromobiphenyl	-	mg/kg	5	ND
Sum of PBDEs	1,000	mg/kg	-	ND
Monobromodiphenyl ether	-	mg/kg	5	ND

This document is issued by the Company under its General Conditions of Service printed overleaf or available on request and accessible at [http://www.sgs.com/terms\\_and\\_conditions.htm](http://www.sgs.com/terms_and_conditions.htm). Attention is drawn to the limitation of liability, indemnification and jurisdiction issues defined therein. Any holder of this document is advised that information contained hereon reflects the Company's findings at the time of its intervention only and within the limits of Client's instructions, if any. The Company's sole responsibility is to its Client and this document does not exonerate parties to a transaction from exercising all their rights and obligations under the transaction documents. Any unauthorized alteration, forgery or falsification of the content or appearance of this document is unlawful and offenders may be prosecuted to the fullest extent of the law. Unless otherwise stated the results shown in this test report refer only to the sample(s) tested. This document cannot be reproduced except in full, without prior approval of the Company.

## Test Report

No. SHAEC1007136603

Date: 31 May 2010

Page 3 of 11

<u>Test Item(s)</u>	<u>Limit</u>	<u>Unit</u>	<u>MDL</u>	<u>002</u>
Dibromodiphenyl ether	-	mg/kg	5	ND
Tribromodiphenyl ether	-	mg/kg	5	ND
Tetrabromodiphenyl ether	-	mg/kg	5	ND
Pentabromodiphenyl ether	-	mg/kg	5	ND
Hexabromodiphenyl ether	-	mg/kg	5	ND
Heptabromodiphenyl ether	-	mg/kg	5	ND
Octabromodiphenyl ether	-	mg/kg	5	ND
Nonabromodiphenyl ether	-	mg/kg	5	ND
Decabromodiphenyl ether	-	mg/kg	5	ND

### Notes :

- (1) The maximum permissible limit is quoted from the document 2005/618/EC amending RoHS directive 2002/95/EC

### Halogen

Test Method : With reference to EN 14582: 2007, analysis was performed by Ion Chromatograph (IC).

<u>Test Item(s)</u>	<u>Unit</u>	<u>MDL</u>	<u>002</u>
Fluorine (F)	mg/kg	50	ND
Chlorine (Cl)	mg/kg	50	ND
Bromine (Br)	mg/kg	50	ND
Iodine (I)	mg/kg	50	ND

### Polychlorinated Naphthalenes (PCNs)

Test Method : With reference to US EPA 8081B: 2007, analysis was performed by GC-MS

<u>Test Item(s)</u>	<u>Unit</u>	<u>MDL</u>	<u>002</u>
2-Chlorinated Naphthalene	mg/kg	5	ND
1,4-Dichlorinated Naphthalene	mg/kg	5	ND
1,5-Dichlorinated Naphthalene	mg/kg	5	ND
1,2-Dichlorinated Naphthalene	mg/kg	5	ND
1,8-Dichlorinated Naphthalene	mg/kg	5	ND
1,2,3-Trichlorinated Naphthalene	mg/kg	5	ND
1,2,3,4-Tetrachlorinated Naphthalene	mg/kg	5	ND
1,2,3,4,6-Pentachlorinated Naphthalene	mg/kg	5	ND
Octa-chlorinated Naphthalene	mg/kg	5	ND

This document is issued by the Company under its General Conditions of Service printed overleaf or available on request and accessible at [http://www.sgs.com/terms\\_and\\_conditions.htm](http://www.sgs.com/terms_and_conditions.htm). Attention is drawn to the limitation of liability, indemnification and jurisdiction issues defined therein. Any holder of this document is advised that information contained hereon reflects the Company's findings at the time of its intervention only and within the limits of Client's instructions, if any. The Company's sole responsibility is to its Client and this document does not operate parties to a transaction from exercising all their rights and obligations under the transaction documents. Any unauthorized alteration, forgery or falsification of the content or appearance of this document is unlawful and offenders may be prosecuted to the fullest extent of the law. Unless otherwise stated the results shown in this test report refer only to the sample(s) tested. This document cannot be reproduced except in full, without prior approval of the Company.

**Short Chained Chlorinated Paraffin (SCCP)**

Test Method : With reference to US EPA 3550C: 2007, analysis was performed by GC-ECD.

<u>Test Item(s)</u>	<u>Unit</u>	<u>MDL</u>	<u>002</u>
Short Chained Chlorinated Paraffin (SCCP)	mg/kg	30	ND

Notes :

- (1) Short Chain Chlorinated Paraffin Reference Information: Entry 42 of Regulation (EC) No 552/2009 amending Annex XVII of REACH Regulation (EC) No 1907/2006 (previously restricted under Directive 2002/45/EC):  
 Shall not be placed on the market, or used as substances, or as constituents of other substances or in mixtures in concentrations greater than 1% by weight, where the substance or mixture is intended for:
  - metalworking
  - fat liquoring of leather
 Please refer to Regulation (EC) No 552/2009 to get more detail information

**Polychlorinated Terphenyls (PCTs)**

Test Method : With reference to US EPA 8082A: 2007, analysis was performed by GC-MS

<u>Test Item(s)</u>	<u>Unit</u>	<u>MDL</u>	<u>002</u>
Aroclor 5432	mg/kg	5	ND
Aroclor 5442	mg/kg	5	ND

Notes :

- (1) PCTs Reference Information: Entry 1 of Regulation (EC) No 552/2009 amending Annex XVII of REACH Regulation (EC) No 1907/2006 (previously restricted under Directive 89/677/EC)  
 Shall not be placed on the market, or used:
  - as substances,
  - In mixtures, including waste oils, or in equipment, in concentrations greater than 50 mg/kg (0,005 % by weight).
 Please refer to Regulation (EC) No 552/2009 to get more detail information

**PFOS (Perfluorooctane Sulfonates) and PFOA (Perfluorooctanoic Acid)**

Test Method : With reference to US EPA 3550C: 2007, analysis was performed by HPLC-MS.

This document is issued by the Company under its General Conditions of Service printed overleaf or available on request and accessible at [http://www.sgs.com/terms\\_and\\_conditions.htm](http://www.sgs.com/terms_and_conditions.htm). Attention is drawn to the limitation of liability, indemnification and jurisdiction issues defined therein. Any holder of this document is advised that information contained hereon reflects the Company's findings at the time of its intervention only and within the limits of Client's instructions, if any. The Company's sole responsibility is to its Client and this document does not exonerate parties to a transaction from exercising all their rights and obligations under the transaction documents. Any unauthorized alteration, forgery or falsification of the content or appearance of this document is unlawful and offenders may be prosecuted to the fullest extent of the law. Unless otherwise stated the results shown in this test report refer only to the sample(s) tested. This document cannot be reproduced except in full, without prior approval of the Company.

## Test Report

No. SHAEC1007136603

Date: 31 May 2010

Page 5 of 11

<u>Test Item(s)</u>	<u>Unit</u>	<u>MDL</u>	<u>002</u>
Perfluorooctane Sulfonates (PFOS) and related Acid, Metal Salt and Amide	mg/kg	10	ND
Perfluorooctyl Acid (PFOA)	mg/kg	10	ND

### Notes :

- (1) PFOS Reference Information: Entry 53 of Regulation (EC) No 552/2009 amending Annex XVII of REACH Regulation (EC) No 1907/2006 (previously restricted under Directive 2006/122/EC)
- (i) May not be placed on the market or used as a substance or constituent of preparations in a concentration equal to or higher than 0.005 % by mass.
- (ii) May not be placed on the market in semi-finished products or articles, or parts thereof, if the concentration of PFOS is equal to or higher than 0.1 % by mass calculated with reference to the mass of structurally or microstructurally distinct parts that contain PFOS or, for textiles or other coated materials, if the amount of PFOS is equal to or higher than 1µg /m<sup>2</sup> of the coated material. Please refer to Regulation (EC) No 552/2009 to get more detail information

### Polychlorinated Biphenyls (PCBs)

Test Method : With reference to US EPA 8082A: 2007, analysis was performed by GC-MS

<u>Test Item(s)</u>	<u>CAS_NO</u>	<u>Unit</u>	<u>MDL</u>	<u>002</u>
2,4,4'-Trichlorobiphenyl (PCB 28)	7012-37-5	mg/kg	0.5	ND
2,2',5,5'-Tetrachloro-biphenyl (PCB 52)	35693-99-3	mg/kg	0.5	ND
2,2',4,5,5'-Pentachloro-biphenyl (PCB 101)	37680-73-2	mg/kg	0.5	ND
2,3',4,4',5-Pentachlorobiphenyl (PCB 118)	31508-00-6	mg/kg	0.5	ND
2,2',3,4,4',5'-Hexachloro-biphenyl (PCB 138)	35065-28-2	mg/kg	0.5	ND
2,2',4,4',5,5'-Hexachloro-biphenyl (PCB 153)	35065-27-1	mg/kg	0.5	ND
2,2',3,4,4',5,5'-Heptachlorobiphenyl (PCB 180)	35065-29-3	mg/kg	0.5	ND

This document is issued by the Company under its General Conditions of Service printed overleaf or available on request and accessible at [http://www.sgs.com/terms\\_and\\_conditions.htm](http://www.sgs.com/terms_and_conditions.htm). Attention is drawn to the limitation of liability, indemnification and jurisdiction issues defined therein. Any holder of this document is advised that information contained hereon reflects the Company's findings at the time of its intervention only and within the limits of Client's instructions, if any. The Company's sole responsibility is to its Client and this document does not operate parties to a transaction from exercising all their rights and obligations under the transaction documents. Any unauthorized alteration, forgery or falsification of the content or appearance of this document is unlawful and offenders may be prosecuted to the fullest extent of the law.

Unless otherwise stated the results shown in this test report refer only to the sample(s) tested. This document cannot be reproduced except in full, without prior approval of the Company.

ATTACHMENTS

RoHS Testing Flow Chart

- 1) Name of the person who made testing: Allen Xiao/ Spring Zuo / Frank Fang /Elim Lin
- 2) Name of the person in charge of testing: Jeff Zhang/George Xu/Tracy Yue
- 3) These samples were dissolved totally by pre-conditioning method according to below flow chart. (Cr<sup>6+</sup> and PBBs/PBDEs test method excluded)

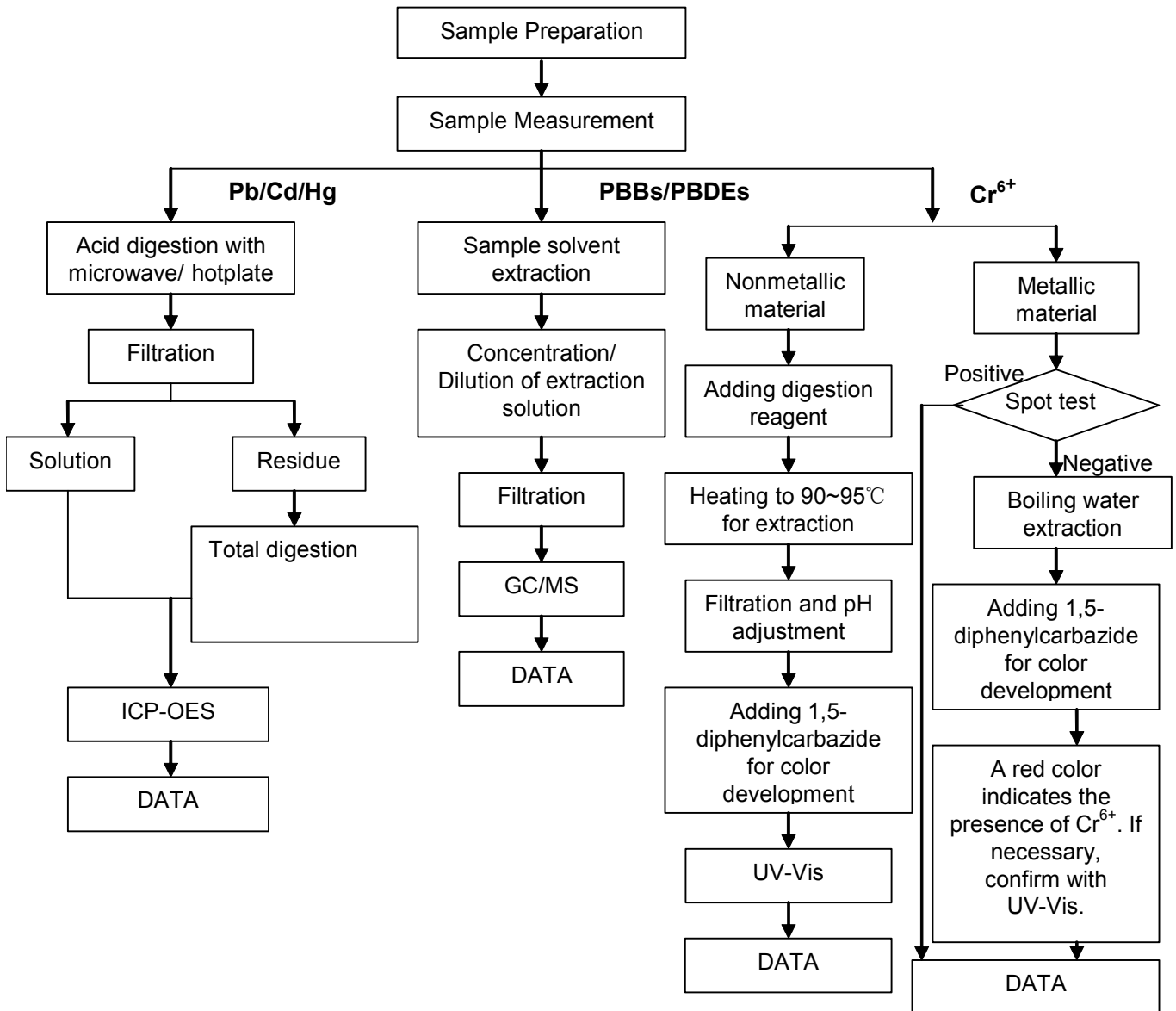

This document is issued by the Company under its General Conditions of Service printed overleaf or available on request and accessible at [http://www.sgs.com/terms\\_and\\_conditions.htm](http://www.sgs.com/terms_and_conditions.htm). Attention is drawn to the limitation of liability, indemnification and jurisdiction issues defined therein. Any holder of this document is advised that information contained hereon reflects the Company's findings at the time of its intervention only and within the limits of Client's instructions, if any. The Company's sole responsibility is to its Client and this document does not operate parties to a transaction from exercising all their rights and obligations under the transaction documents. Any unauthorized alteration, forgery or falsification of the content or appearance of this document is unlawful and offenders may be prosecuted to the fullest extent of the law. Unless otherwise stated the results shown in this test report refer only to the sample(s) tested. This document cannot be reproduced except in full, without prior approval of the Company.



## SCCP Testing Flow Chart

- 1) Name of the person who made testing: Bill Zhong
- 2) Name of the person in charge of testing: Susan Liu

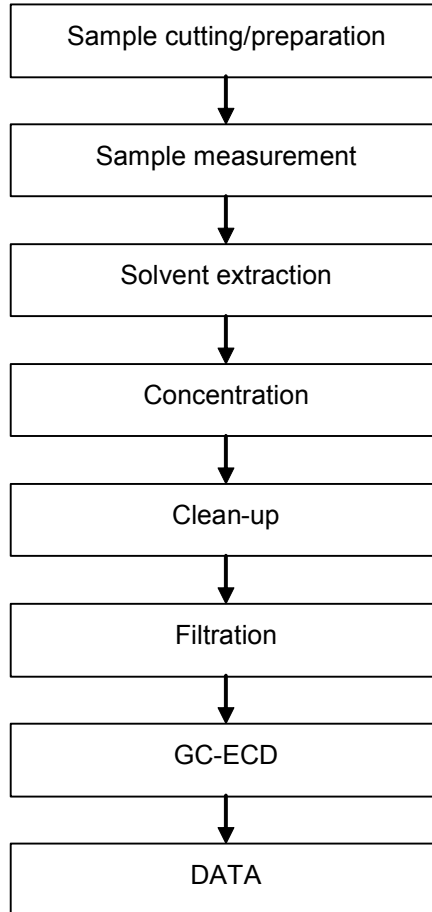

This document is issued by the Company under its General Conditions of Service printed overleaf or available on request and accessible at [http://www.sgs.com/terms\\_and\\_conditions.htm](http://www.sgs.com/terms_and_conditions.htm). Attention is drawn to the limitation of liability, indemnification and jurisdiction issues defined therein. Any holder of this document is advised that information contained hereon reflects the Company's findings at the time of its intervention only and within the limits of Client's instructions, if any. The Company's sole responsibility is to its Client and this document does not exonerate parties to a transaction from exercising all their rights and obligations under the transaction documents. Any unauthorized alteration, forgery or falsification of the content or appearance of this document is unlawful and offenders may be prosecuted to the fullest extent of the law. Unless otherwise stated the results shown in this test report refer only to the sample(s) tested. This document cannot be reproduced except in full, without prior approval of the Company.





Sample photo:



SGS authenticate the photo on original report only

\*\*\* End of Report \*\*\*

This document is issued by the Company under its General Conditions of Service printed overleaf or available on request and accessible at [http://www.sgs.com/terms\\_and\\_conditions.htm](http://www.sgs.com/terms_and_conditions.htm). Attention is drawn to the limitation of liability, indemnification and jurisdiction issues defined therein. Any holder of this document is advised that information contained hereon reflects the Company's findings at the time of its intervention only and within the limits of Client's instructions, if any. The Company's sole responsibility is to its Client and this document does not exonerate parties to a transaction from exercising all their rights and obligations under the transaction documents. Any unauthorized alteration, forgery or falsification of the content or appearance of this document is unlawful and offenders may be prosecuted to the fullest extent of the law. Unless otherwise stated the results shown in this test report refer only to the sample(s) tested. This document cannot be reproduced except in full, without prior approval of the Company.

<p><b>Kostat, Inc.</b>                  358-15, Gogange-Dong, Ojung-gu,                  Buchun-City Kyoung Ki-Do, Korea                  Tel: 82-32-671-8100                  Fax: 82-32-671-0259</p>	<b>M S D S</b>	Issue Date	2010.03.03
	[Material Safety Data Sheet]	Revision date	2010.05.03
	<b>Carrier tapes</b>	Valid date	2012.05.03
	<b>KKB</b>	Page	1/4

**1. PRODUCT AND COMPANY IDENTIFICATION**

Product Name	Carrier tapes
Ext. Appearance	Thermoforming Poly Styrene sheet
Purpose/Use	May be use to produce molding or extruded particles or as a compound of other industrial products
Manufacture	Kostat, Inc., 49, Wonsan-Ri, Hasung-Myun, Gimpo-City, Kyoung Ki-Do, Korea
Contact	(Tel) 82-31-988-2350 (Fax) 82-31-988-2354

**2. COMPOSITION/INFORMATION ON INGREDIENTS**

Chemical Name	Common Name	CAS No.	Content (%)
High Impact Polystyrene	HIPS	9003-53-6	60~65
Styrene Butadiene Copolymer	SBS	9003-55-8	10~15
Carbon Black	Carbon Black	1333-86-4	20~25
Anti Oxidant	A/O	6683-19-8	0.5~1.0

**3. HAZARDS IDENTIFICATION**

**EMERGENCY OVERVIEWS**

Sheets have slight or no odor.

Can burn in a fire creating dense toxic smoke. Molten plastic can cause severe thermal burns.

Fumes produced during melt processing may cause eye, skin and respiratory tract irritation.

**POTENTIAL HEALTH EFFECTS**

Eye Product may cause irritation or injury due to mechanical action.

Skin Pellets not likely to cause skin irritation.

Ingestion Not acutely toxic.

**CHRONIC/CARCINOGENICITY**

NTP: Not Tested

OSHA: Not Regulated

IARC: Not Listed

**4. FIRST AID MEASURES**

Eye	Remove contact lenses at once, immediately. Flush eyes well with copious quantities of water or normal saline for at least 15-20 minutes. If irritation persists, seek medical attention.
Skin	Seek medical attention if rash or burn occurs.
Inhalation	Not likely to be inhaled due to physical form.
Ingestion	Not probable. If a large amount is swallowed, seek medical attention.

**MELT PROCESSING**

For molten plastic skin contact, cool rapidly flush water and immediately seek medical attention. For skin contact with fume commiserate, immediately each thoroughly with soap and water. If irritation develops seek medical attention.

**5. FIRE FIGHTING MEASURES**

Approved pressure demand breathing apparatus and protective clothing should be used for all fires. Water spray is the preferred extinguishing medium. This product will melt but will not be carried on the surface for water.

**EXTINGUISHING MEDIA**

Water spray and foam, water is the best extinguishing medium.

**HAZARDOUS COMBUSTION PRODUCTS**

Hazardous combustion products may include intense heat, dense black smoke, carbon monoxide, carbon dioxide, oxides of phosphorus, hydrogen cyanide, hydrocarbon fragments, hydrogen fluoride, carbonyl fluoride and fluorocarbon fragments.

**6. ACCIDENTAL RELEASE MEASURES**

Sweep or gather up material and place in container for disposal or recovery.[see section 13]

**7. HANDING AND STORAGE**

Handing	Follow recommendations on label in processing guide. Prevent contact with skin and eyes. Use good industrial hygiene practices. Provide adequate ventilation.
Storage	Store in a dry place away from moisture, excessive heat and sources of ignition.

**8. EXPOSURE CONTROLS/PERSONAL PROTECTION**

A continuous supply of fresh air to the workplace together with removal of processing fumes through exhaust systems is recommended. Processing fume condensate may be a fire hazard and toxic remove periodically from exhaust hoods, ducts work and other surfaces using appropriate.

**PERSONAL PROTECTION**

Eye/Face Protection	Wear safety glasses or goggles to protect against dust particles.
Skin Protection	Wear chemical resistant gloves and protective clothing.
Respiratory Protection	Use NIOSH approved respirator as needed to mitigate exposure.
Engineering Controls	Work in well ventilated areas. Do not breathe dust.

**9. PHYSICAL AND CHEMICAL PROPERTIES**

Physical Form	Solid
Color and Appearance	Plastic pellet with slight odor
Boiling Point	Not Applicable
Specific Gravity (WATER=1)	1.15 ~ 1.20
Water Solubility	Insoluble
PH	Not Applicable
Odor threshold	Not established

**10. STABILITY AND REACTIVITY**

Stability	Stable
Incompatibility	Strong oxidizing agents, strong acids, strong bases
Hazardous decomposition Products	Not decomposition expected under normal storage conditions.
Do not exceed melt temperature recommendations in product literature.	

**11. TOXICOLOGICAL INFORMATION**

Not available

**12. ECOLOGICAL INFORMATION**

Not expected to present any significant ecological problems.

**13. DISPOSAL CONSIDERATIONS**

Waste Disposal	Recycling is encouraged. Landfill or incinerate in accordance with federal, state and local requirements. Collected processing fume condensates and incinerator ash should be tested to determine waste classification.
----------------	---

**14. TRANSPORT INFORMATION**

This product is not regulated as a hazardous material for transport

Sea Free for any transport

Air Free for any transport

**15. REGULATORY INFORMATION**

Listed below are chemical substances subject to supplier notification requirements.

U.S. Regulations

TSCA Inventory This product complies with the chemical substance inventory requirements of the US EPA TSCA

CERCLA SECTION 103 Not Listed

SARA SECTION 313 Not Listed

STATE REGULATIONS Not Listed

EUROPEAN REGULATIONS Not Assigned

**16. OTHER INFORMATION**

The information submitted in this MSDS is based on our current knowledge and experience.

Because it is not possible to anticipate all conditions of use additional safety precautions may be required, we make no warranty.

ABBREVIATIONS:

ACGIH American Conference of Governmental industrial Hygienist

DOT Department of transportation

EC European Communities

EPA Environmental Protection Agency

IARC International Agency for Research on Cancer.

NOISH National Institute for Occupational Safety and Health

NTP National Toxicology Program

OSHA Occupational Safety and Health Administration

RTECS Registry of Toxic Effects of Chemical Substances

CAS# Chemical Abstracts Service Number

RCRA Resource Conservation and Recovery Act

## MATERIAL SAFETY DATA SHEET

-----  
MANUFACTURER INFORMATION

MANUFACTURER : Denki Kagaku Kogyo Kabushiki Kaisya  
SECTION IN CHARGE : Electronic Packaging Materials Department  
Electronic Materials Business Division  
ADDRESS : Nihonbashi Mitsui Tower,1-1,Nihonbashi-Muromachi 2-chome,Chuo-ku,  
Tokyo 103-8338,JAPAN  
EMERGENCY PHONE No. : 81-3-5290-5383 (voice)  
81-3-5290-5306 (fax)

-----  
PRODUCT NAME : Denka thermofilm ALS-PRA  
-----

## COMPOSITION / INFORMATION ON INGREDIENTS

## DISTINCTION OF SINGLE PRODUCT OR MIXTURE

: mixture (layered)  
INGREDIENT : Polyethyleneterephthalate resin  
: Polyolefinic resin  
: Polyolefinic resin

-----  
HAZARDS IDENTIFICATION

## =====

Emergency overview  
Odorless translucent film. Can burn in a fire.

-----  
POTENTIAL HEALTH EFFECTS AND FIRST AID MEASURES

EYE : In usual handling, this does not go into an eye. When entering, it may damage an eyeball. Wash an eye with pure water and go to doctor.  
SKIN : There is usually no skin obstacle by contact. If abnormalities occur, flush the skin with pure water and go to doctor.  
Cutting of the skin may be carried out when the skin is strongly rubbed with the edge of a film.  
INHALATION : Gas may have occurred by high temperature during heat sealing. When inhaling this gas severely, move to the place of fresh air and gargle simultaneously. When coughing and breath difficulty will occur, go to doctor.

INGESTION : Ingestion does not happen in usual handling. If little, it does not need special action. If abundant, makes vomit.

---

#### FIRE FIGHTING MEASURES

Sever the source of combustion like a general fire, and extinguish the fire using a lot of water and a fire-extinguisher.

In case of fire, black smoke and carbon monoxide, etc. may occur by heat decomposition and imperfect combustion of polymer ingredient. Use suitable protection implement for avoiding risks of inhaling those and barring a field of view for injury on fire-extinguishing activity.

---

#### ACCIDENTAL RELEASE MEASURES

Sweep or vacuum material and place in a disposal container.

---

#### HANDLING AND STORAGE

HANDLING : Although there is no fear such as ignition, combustion, and explosion in normal temperature, it can burn at high temperature.  
Since this material is a roll-like film with heavy weight, take caution in fall up to a leg etc.  
Cutting of the skin may be carried out when the skin is strongly rubbed with the edge of a film.

STORAGE : Storage in room at normal temperature and avoid to expose by rain, wind, and direct sunshine.

---

#### EXPOSURE CONTROLS / PERSONAL PROTECTION

MANAGEMENT CONCENTRATION : Not applicable

PERMISSION CONCENTRATION : Not defined

MEASURE AGAINST EQUIPMENT : Not necessary

PROTECTION : Not necessary at usual handling

---

#### PHYSICAL AND CHEMICAL PROPERTIES

APPEARANCE : Translucent plastic film

SPECIFIC GRAVITY : 1.05~1.07

MELTING POINT : Since this material is a mixture, it does not exist clearly.

SOLUBILITY IN WATER : Not applicable

---

#### STABILITY AND REACTIVITY

FLUSH POINT : No data available  
IGNITING POINT : There are not natural ignition nature and ignition nature by the reactivity with water.  
INFLAMMABILITY : Yes  
OXIDIZING : No  
SELF-REACTIVITY : No  
VOLATILITY : No  
DUST EXPLOSION : Not applicable  
STABILITY AND REACTIVITY : Stable and deficient in reactivity

---

#### TOXICOLOGICAL INFORMATION

Although there is no knowledge now, the following view is appropriate.

STIMULUS NATURE : Physical stimulus  
ACUTE TOXICITY : Inactive physiologically and there is no special acute action to a human body.

---

#### ECOLOGICAL INFORMATION

Decomposition nature, accumulation nature, and fish

TOXICITY : Not applicable  
OTHERS : Since a film is considered to be stable that it is hard to decompose, it must not be abandoned anywhere to prevent that a sea living thing and birds take in.

---

#### DISPOSAL CONSIDERATION

##### WASTE MANAGEMENT INFORMATION (DISPOSAL)

: Any disposal practice must be in compliance with local, state, and federal laws and regulations (contact local or state environmental agency for specific rules).

---

#### TRANSPORT INFORMATION

Ensure shipping and load to prevent collapse and damage.

---

#### REGULATORY INFORMATION

##### OSHA HAZARD COMMUNICATION RULES

: This product contains no substances under this rules.

---