



OPTREX America Inc.
46723 Five Mile Road
Plymouth, MI 48170 USA
(734) 416-8500
www.optrex.com

T-55264, T-55265, T-55520, and T-55548 TFT MODULES

TECHNICAL NOTE

DATE: 12-14-2011

REV: 1.0

The Optrex 5.7" QVGA and VGA module families - T-55264, T-55265, T-55520, and T-55548 – utilize a driver set that requires a RISING edge DOTCLK data latch.

This is an issue because the majority of TFT displays on the market utilize a FALLING edge DOTCLK data latch. The Optrex T-51750 6.5" VGA module family utilizes a falling edge latch.

These displays “may” work with the incorrect falling edge DOTCLK orientation, but display line noise or horizontal display image distortion has been reported.

The DOTCLK “phase” must be correctly tied to the DENA and DATA signals.

Please see the attached timing chart below showing the correct relation of the DOTCLK signal to the DATA and the DENA data enable signals.

RISING EDGE DOTCLK TIMING

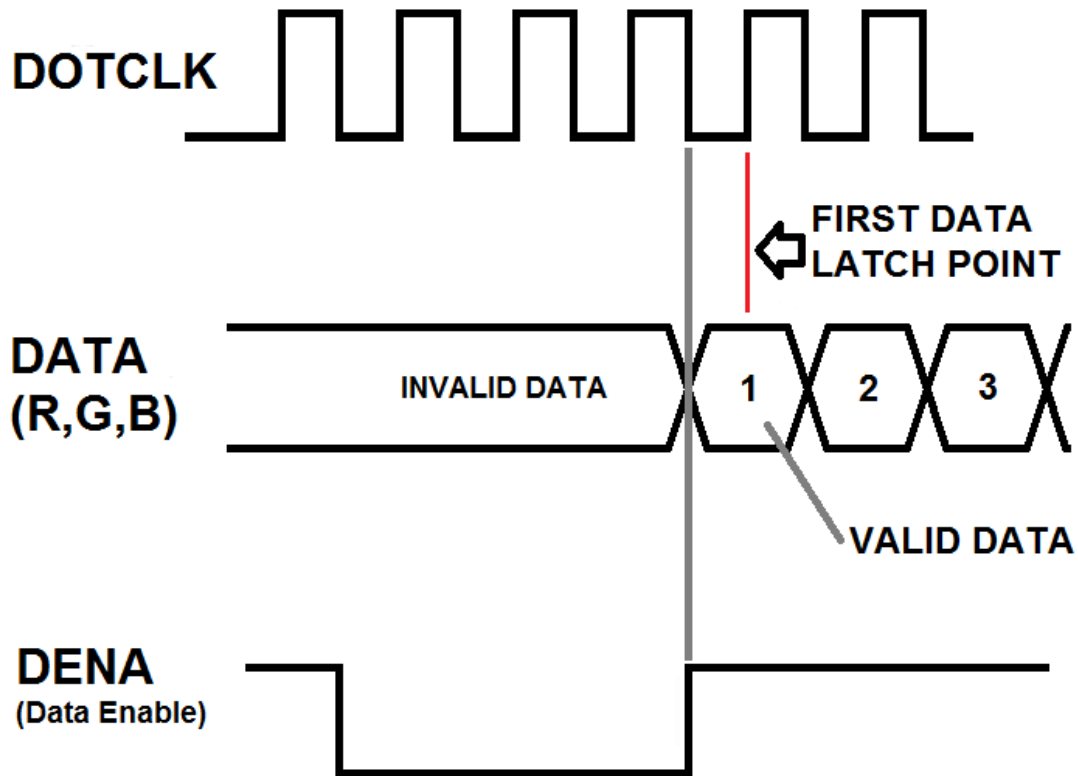

Please check and make sure the DOTCLK timing orientation to DENA and DATA signals matches the graph above. If DOTCLK is shifted by one-half clock cycle, the data will be latched on the FALLING EDGE and may result in display noise.

If your system currently uses a DOTCLK orientation where the DENA signal and DOTCLK signal both line up on rising edges it is using a FALLING latch orientation and the DOTCLK timing will need to be modified or inverted.